

<b>D</b>	<b>Bedienungsanleitung</b>	<b>2</b>
<b>GB</b>	<b>Operating instructions</b>	<b>14</b>
<b>F</b>	<b>Instructions de service</b>	<b>26</b>
<b>E</b>	<b>Instrucciones de uso</b>	<b>38</b>
<b>I</b>	<b>Istruzioni per l'uso</b>	<b>50</b>
<b>NL</b>	<b>Gebruiksaanwijzing</b>	<b>62</b>
<b>PL</b>	<b>Instrukcja obsługi</b>	<b>74</b>
<b>N</b>	<b>Bruksanvisning</b>	<b>86</b>

07.2017

**Digital 528**



## D Bedienungsanleitung



### 1. Zu diesem Produkt

- Originalanleitung.
- Teil des Produkts.
- Unbedingt zu lesen und aufzubewahren.
- Urheberrechtlich geschützt.
- Nachdruck, auch auszugsweise, nur mit unserer Genehmigung.
- Änderungen, die dem technischen Fortschritt dienen, vorbehalten.
- Darstellungen sind nicht maßstabsgetreu.

#### Vereinfachte EU-Konformitätserklärung

Hiermit erklärt Marantec Antriebs- und Steuerungstechnik GmbH & Co. KG, dass der Funkanlagentyp Digital 528 der Richtlinie 2014/53/EU entspricht.

Der vollständige Text der EU-Konformitätserklärung ist unter der folgenden Internetadresse verfügbar:

[www.marantec.com](http://www.marantec.com)



### WARNUNG!

#### Verletzungsgefahr durch unkontrollierte Torbetätigung!

- Betätigen Sie die Steuerung oder den Handsender nur, wenn sich keine Personen oder Gegenstände im Bewegungsbereich des Tores befinden.
- Stellen Sie sicher, dass Steuerung und Handsender nicht von Kindern oder unbefugten Personen benutzt werden.
- Stellen Sie sicher, dass der Handsender nicht versehentlich betätigt wird (z. B. in der Hosentasche).



### VERWEIS

Die Dokumentation des Antriebs oder Empfängers muss beachtet werden. Nützliche Informationen und eine Videoanleitung zur Einrichtung des Geräts sind im FAQ-Bereich auf folgender Website abrufbar:

[www.marantec.com](http://www.marantec.com)

## 2. Produktübersicht

### 2.1 Lieferumfang

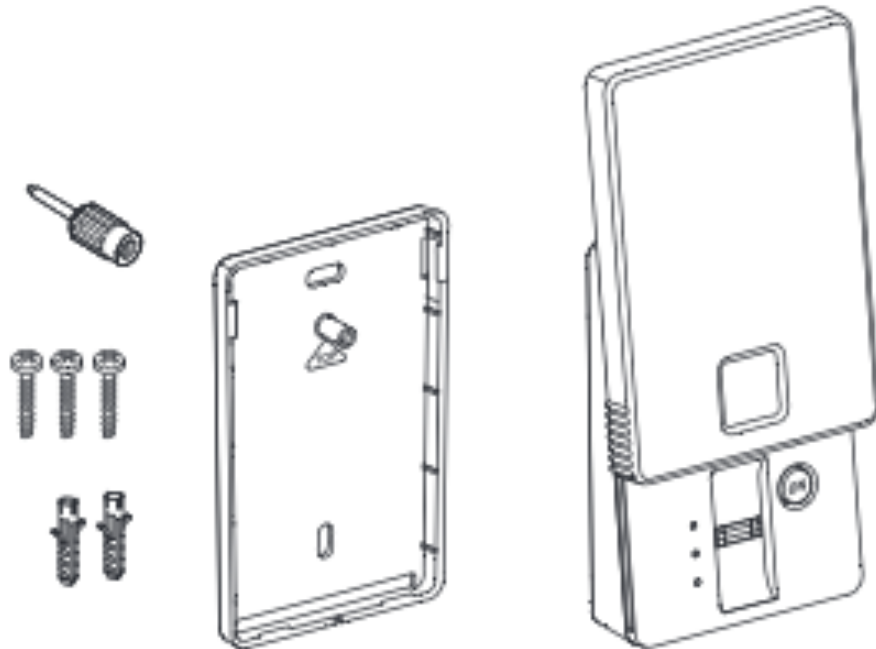

### 2.2 Montage

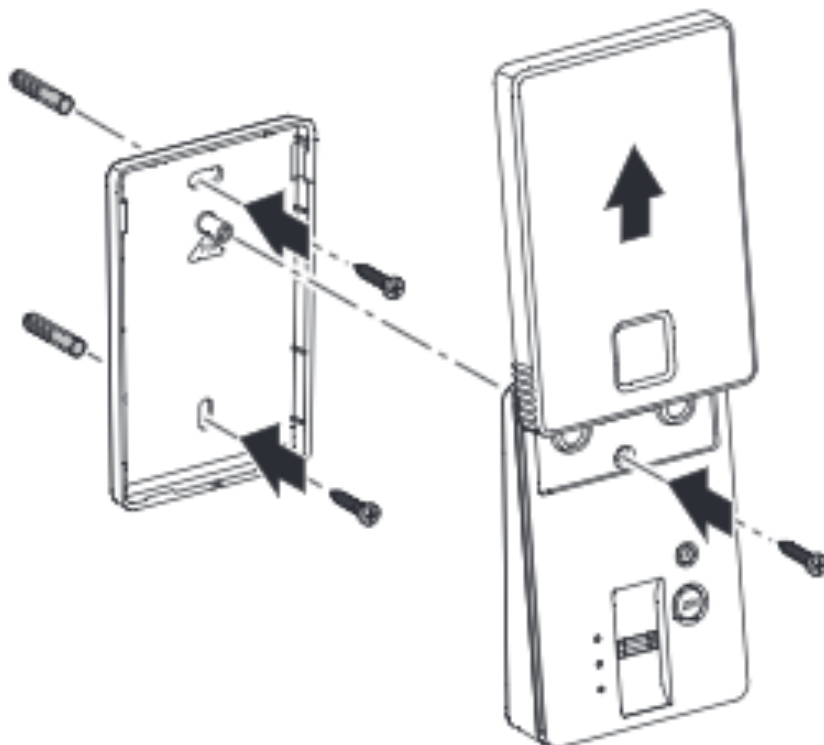

## 2.3 Übersicht

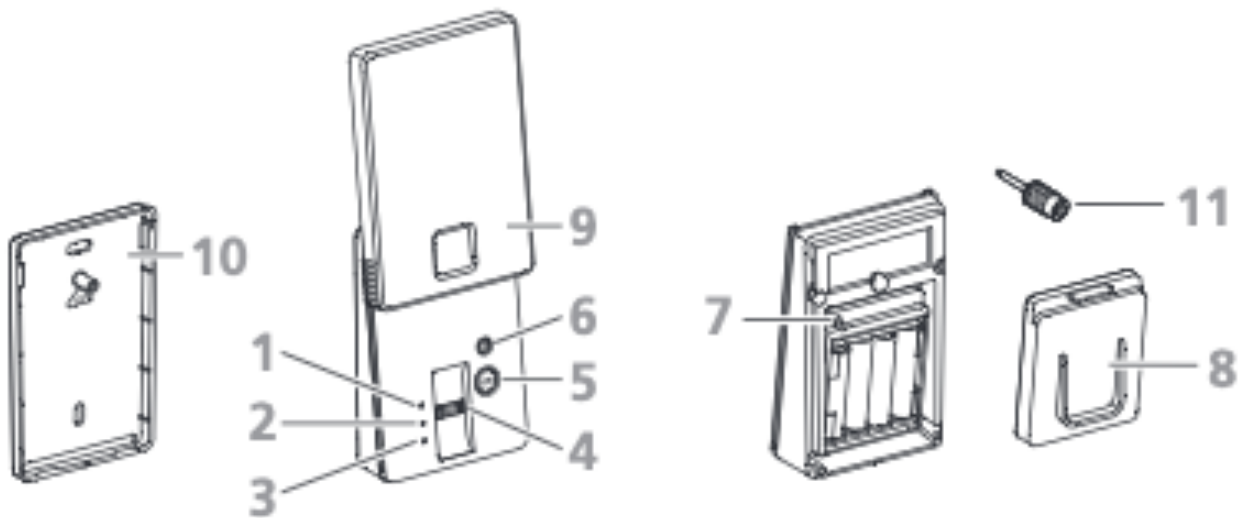

### Legende

- |   |                       |    |  |
|---|-----------------------|----|--|
| 1 | LED-Anzeige rot       | 7  | Hintere Programmierstaste                      |
| 2 | LED-Anzeige gelb      | 8  | Batteriefachdeckel                             |
| 3 | LED-Anzeige grün      | 9  | Abdeckung                                      |
| 4 | Lesemodul             | 10 | Wandhalter                                     |
| 5 | Power-Taste (ON)      | 11 | Programmierstift für hintere Programmierstaste |
| 6 | Programmierstaste (P) |    |  |

## 2.4 LED-Anzeigen



LED aus



LED blinkt langsam



LED leuchtet



LED blinkt schnell



LED flackert



LED blinkt doppelt und schnell

### 3. Inbetriebnahme

- 2 Master-Finger gewähren Zugang zu den Programmierfunktionen.
- 20 Nutzer-Finger können eingelesen werden, verteilt auf 2 Funk-Kanäle (A + B). Jeder Funk-Kanal kann eine Antriebsfunktion oder einen Antrieb bedienen.















#### 3.1 Master-Finger einlernen

- Nur bei Erstinbetriebnahme oder nach Reset notwendig.
- Es müssen 2 verschiedene Master-Finger eingelesen werden, um die Programmierung erfolgreich zu beenden.
- Master- und Nutzer-Finger müssen unterschiedliche Finger sein.

1.	<ul style="list-style-type: none"> <li>• Abdeckung aufschieben oder Power-Taste (ON) betätigen.</li> <li>- Kein Master-Finger eingelesen.</li> </ul>		<b>20 s</b>
2.	<ul style="list-style-type: none"> <li>• Neuen Master-Finger 1 vollständig über das Lesemodul ziehen.</li> </ul>		<b>2 s</b>
3.	<ul style="list-style-type: none"> <li>- Kein Master-Finger 2 eingelesen.</li> </ul>		<b>20 s</b>
4.	<ul style="list-style-type: none"> <li>• Neuen Master-Finger 2 vollständig über das Lesemodul ziehen.</li> </ul>		<b>2 s</b>
5.	<ul style="list-style-type: none"> <li>- Gerät wechselt in Betriebsbereitschaft.</li> </ul>		<b>20 s</b>

### 3.2 Nutzer-Finger einlernen

- Ein Nutzer-Finger darf nicht bereits als Master-Finger verwendet werden, damit eine dauerhafte und korrekte Funktion gewährleistet ist.
- Ist der Speicher voll (20 Nutzer-Finger) erscheint eine Warnmeldung.
- Einen vorhandenen Nutzer-Finger löschen und das Einlernen nochmals durchführen, oder
- das Einlernen ohne vorheriges Löschen nochmals durchführen. Der neue Nutzer-Finger wird gespeichert und ersetzt den 1. eingelernten Nutzer-Finger. Jeder weitere eingelernte Nutzer-Finger überschreibt den 2., 3., 4. etc..

1.	<ul style="list-style-type: none"> <li>• Abdeckung komplett aufschieben oder Power-Taste (ON) betätigen.</li> <li>– Gerät wechselt in Betriebsbereitschaft.</li> </ul>	  	20 s
2.	<ul style="list-style-type: none"> <li>• Programmier Taste (P) 4 Sekunden gedrückt halten.</li> </ul>	  	20 s 20 s
3.	<ul style="list-style-type: none"> <li>• Gültigen Master-Finger vollständig über das Lesemodul ziehen.</li> </ul>	  	20 s 20 s 2 s
4.	Funk-Kanal A	  	20 s 20 s
5.	<p>Funk-Kanal A:</p> <ul style="list-style-type: none"> <li>• Neuen Nutzer-Finger vollständig über das Lesemodul ziehen.</li> <li>– Weitere Nutzer-Finger können nacheinander eingelernt werden. Schritt 5 solange wiederholen, bis alle Nutzer-Finger für Funk-Kanal A eingelernt sind.</li> </ul>	  	20 s 20 s 2 s



**Mögliche Fehler**

- Nutzer-Finger oder unbekannter Finger eingelesen, der Programmiermodus wird sofort beendet.
- Schritte erneut durchführen.
  
- Speicher voll, der Programmiermodus wird sofort beendet.
- Nicht benötigten Nutzer-Finger löschen und Schritte erneut durchführen, oder
- Solange die gelbe LED noch leuchtet Schritte erneut durchführen um einen vorhandenen Finger zu überschreiben. Um mehrere Finger zu überschreiben, muss dieser Prozess jedes Mal neu begonnen werden.



<p><b>6.</b> Wechsel auf Funk-Kanal B (optional):</p> <ul style="list-style-type: none"> <li>• Programmier Taste (P) betätigen.</li> </ul>	
--	--

<p><b>7.</b> Funk-Kanal B:</p> <ul style="list-style-type: none"> <li>• Neuen Nutzer-Finger vollständig über das Lesemodul ziehen.</li> <li>– Weitere Nutzer-Finger können nacheinander eingelesen werden. Schritt 7 solange wiederholen, bis alle Nutzer-Finger für Funk-Kanal B eingelesen sind.</li> </ul>	
---	--

**Mögliche Fehler**

- siehe Punkt 5

<p><b>8.</b></p> <ul style="list-style-type: none"> <li>• Warten bis die rote LED erlischt oder Programmier Taste (P) 4 Sekunden gedrückt halten.</li> <li>– Gerät wechselt in Funktionsbereitschaft.</li> </ul>	
--	--

### 3.3 Gerät einlernen

- Das Gerät verfügt über zwei Funk-Kanäle (A + B). Über einen im Gerät eingelernten Nutzer-Finger wird der jeweilige Funk-Kanal im Antrieb oder der Steuerung eingelernt.

- Gerät von der Wand demontieren.
  - Batteriefachdeckel abnehmen.

- Antrieb, Steuerung oder Empfänger in Funk-Lernbereitschaft bringen. An Antrieb/Steuerung blinkt das Funksymbol .



Die Dokumentation des Antriebs oder Empfängers muss beachtet werden.

- Abdeckung aufschieben oder Power-Taste (ON) betätigen.
  - Gerät wechselt in Betriebsbereitschaft.



- Hintere Programmier Taste betätigen.



- Gültigen Master-Finger vollständig über das Lesemodul ziehen.



#### Mögliche Fehler

- Nutzer-Finger oder unbekannter Finger eingelesen, der Programmiermodus wird sofort beendet.
- Schritte erneut durchführen.





6.	<ul style="list-style-type: none"> <li>• Gültigen Nutzer-Finger vollständig über das Lesemodul ziehen.</li> <li>– Ein Lerntelegramm wird ausgesendet.</li> </ul>	<div style="display: flex; flex-direction: column; align-items: center;"> <div style="margin-bottom: 5px;"><input type="radio"/></div> <div style="margin-bottom: 5px;"><input checked="" type="radio"/></div> <div style="margin-bottom: 5px;"><input checked="" type="radio"/></div> </div> <div style="display: flex; align-items: center; margin-top: 5px;"> <div style="margin-right: 10px;"><b>20 s</b></div> </div> <div style="display: flex; align-items: center; margin-top: 5px;"> <div style="margin-right: 10px;"><b>2 s</b></div> </div>
<b>Mögliche Fehler</b>		<div style="display: flex; flex-direction: column; align-items: center;"> <div style="margin-bottom: 5px;"><input checked="" type="radio"/></div> <div style="margin-bottom: 5px;"><input type="radio"/></div> <div style="margin-bottom: 5px;"><input type="radio"/></div> </div> <div style="display: flex; align-items: center; margin-top: 5px;"> <div style="margin-right: 10px;"><b>2 s</b></div> </div>
7.	– Gerät wechselt in Nutzerbereitschaft.	<div style="display: flex; flex-direction: column; align-items: center;"> <div style="margin-bottom: 5px;"><input type="radio"/></div> <div style="margin-bottom: 5px;"><input checked="" type="radio"/></div> <div style="margin-bottom: 5px;"><input type="radio"/></div> </div> <div style="display: flex; align-items: center; margin-top: 5px;"> <div style="margin-right: 10px;"><b>20 s</b></div> </div>
8.	Die Funk-Lernbereitschaft an Antrieb, Steuerung oder Empfänger beenden. An Antrieb/Steuerung erlischt das Funksymbol .	
		Die Dokumentation des Antriebs oder Empfängers muss beachtet werden.
9.	– Zum Einlernen von Funk-Kanal B Schritte erneut durchführen und Nutzer-Finger für Funk-Kanal B einlesen.	
10.	<ul style="list-style-type: none"> <li>• Batteriefachdeckel montieren.</li> <li>• Gerät an die Wand montieren.</li> </ul>	

## 4. Bedienung

### 4.1 Funktion auslösen

1.	<ul style="list-style-type: none"> <li>• Abdeckung aufschieben oder Power-Taste (ON) betätigen.</li> <li>– Gerät wechselt in Nutzerbereitschaft.</li> </ul>	<div style="display: flex; flex-direction: column; align-items: center;"> <div style="margin-bottom: 5px;"><input type="radio"/></div> <div style="margin-bottom: 5px;"><input checked="" type="radio"/></div> <div style="margin-bottom: 5px;"><input type="radio"/></div> </div> <div style="display: flex; align-items: center; margin-top: 5px;"> <div style="margin-right: 10px;"><b>20 s</b></div> </div>
----	---	---

2.	<ul style="list-style-type: none"> <li>• Gültigen Nutzer-Finger vollständig über das Lesemodul ziehen.</li> <li>– Bei 10 x Blinken die Batterien wechseln.</li> </ul>		1 x	
			10 x	
	<b>Mögliche Fehler</b>		2 s	
	<ul style="list-style-type: none"> <li>– Unbekannter Finger.</li> <li>– Master-Finger eingelesen.</li> </ul>			

## 4.2 Nutzer-Finger löschen

1.	<ul style="list-style-type: none"> <li>• Abdeckung aufschieben oder Power-Taste (ON) betätigen.</li> <li>– Gerät wechselt in Betriebsbereitschaft.</li> </ul>		20 s	
2.	<ul style="list-style-type: none"> <li>• Programmier-taste (P) 4 Sekunden gedrückt halten.</li> </ul>		20 s	
3.	<ul style="list-style-type: none"> <li>• Programmier-taste (P) 4 Sekunden gedrückt halten.</li> </ul>		20 s	
4.	<ul style="list-style-type: none"> <li>• Gültigen Master-Finger vollständig über das Lesemodul ziehen.</li> </ul>		20 s	
	<b>Mögliche Fehler</b>		2 s	
	<ul style="list-style-type: none"> <li>– Unbekannter Finger eingelesen, der Programmiermodus wird sofort beendet.</li> <li>• Schritte erneut durchführen</li> </ul>			

5.	<b>Einzelnen Nutzer-Finger löschen</b>		20 s
	• Zu löschenden Nutzer-Finger vollständig über das Lesemodul ziehen.		20 s
			2 s
	<b>Alle Nutzer-Finger löschen</b>		20 s
	• Programmier Taste (P) betätigen.		20 s
			> 2 s
6.	– Gerät wechselt in Nutzerbereitschaft bzw. Funktionsbereitschaft.		
			20 s
			

### 4.3 Reset

– Alle Master- und Nutzer-Finger werden gelöscht und neue Funkcodes generiert.

1.
  - Gerät von der Wand demontieren.
  - Batteriefachdeckel abnehmen.
  - Abdeckung aufschieben.
  - Eine Batterie entnehmen.

2.
  - Bei gedrückter hinterer Programmier Taste Batterie wieder einsetzen.
  - Hintere Programmier Taste loslassen.



3.
  - Gerät ist auf Werkseinstellungen zurückgesetzt.
  - Kein Master-Finger eingelernt.
  - Neue Master-Finger einlernen.



## 4.4 Batterie wechseln

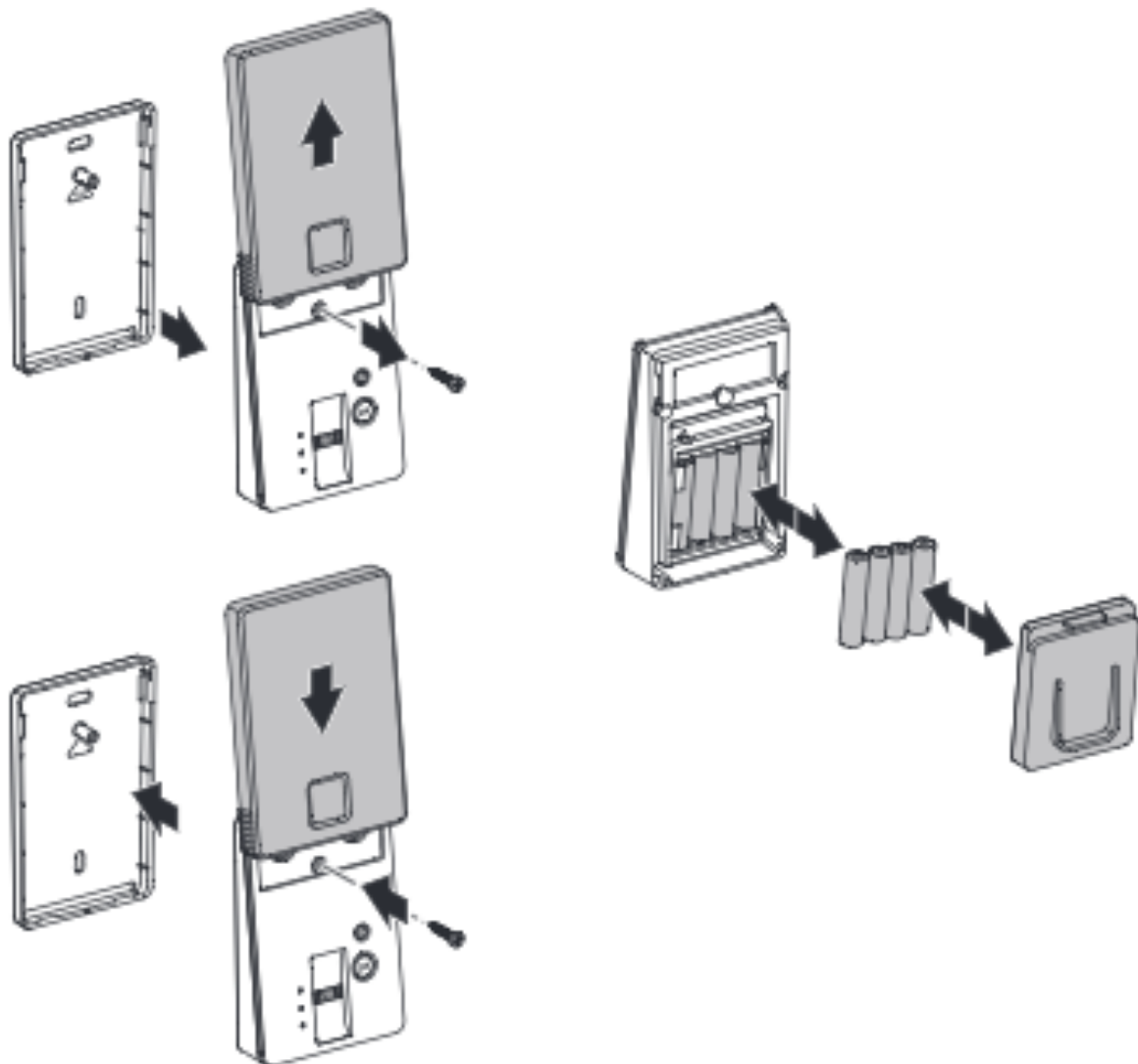

Altgeräte und Batterien dürfen nicht mit dem Hausmüll entsorgt werden!



## 5. Belegung

Eine Tabelle zum Eintragen der Master- und Nutzer-Finger befindet sich am Ende des Dokuments.

## 6. Technische Daten



AAA, 1,5V



°C

-20



°C

+60



IP54



868,3 MHz (max. 0,15 mW)  
433,92 MHz (max. 0,13 mW)

## GB Operating instructions



### 1. Regarding this product

- Original instruction manual.
- Part of the product.
- Must be read and stored without fail.
- Protected by copyright.
- No part of this manual may be reproduced without our prior approval.
- Subject to alterations in the interest of technical progress.
- The illustrations are not true to scale.

#### Simplified EU declaration of conformity

Hereby, Marantec Antriebs- und Steuerungstechnik GmbH & Co. KG declares that the radio equipment type Digital 528 is in compliance with Directive 2014/53/EU. The full text of the EU declaration of conformity is available at the following internet address: [www.marantec.com](http://www.marantec.com)



#### WARNING!

##### **Danger of injury due to uncontrolled operation of the door!**

- Operate the controls or the hand transmitter only when there are no persons or objects in the path of the door.
- Ensure that the controls and the hand transmitter are never used by children or unauthorised persons.
- Ensure that the hand transmitter cannot be operated by accident (in a trouser pocket, for example).



#### REFERENCE

The documentation supplied with the opener or receiver must be observed. Useful information and an instruction video for setting up the device are available in the FAQ area of the following website: [www.marantec.com](http://www.marantec.com)



## 2. Product overview

### 2.1 Scope of supply

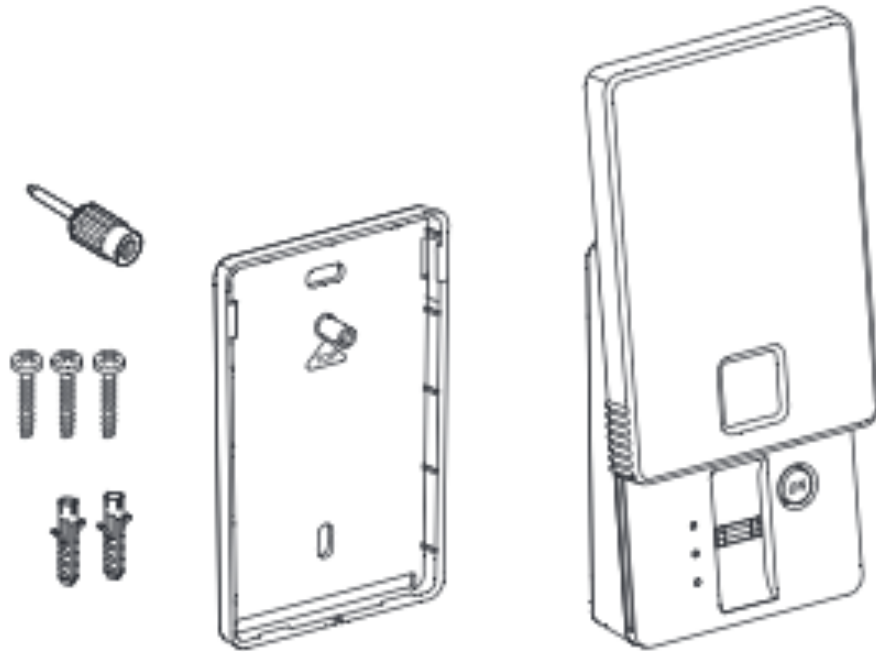

### 2.2 Installation

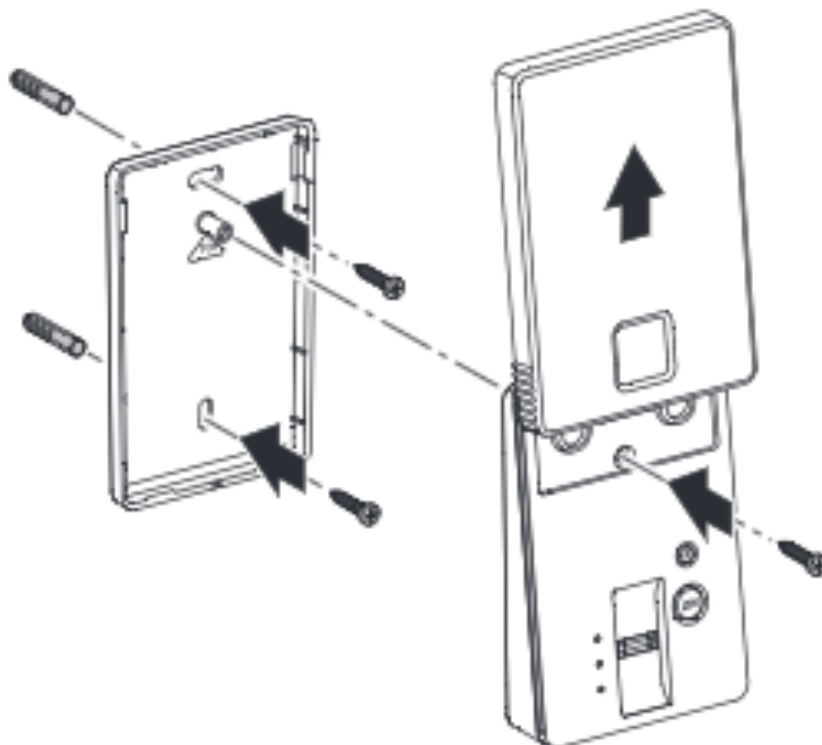

## 2.3 Overview

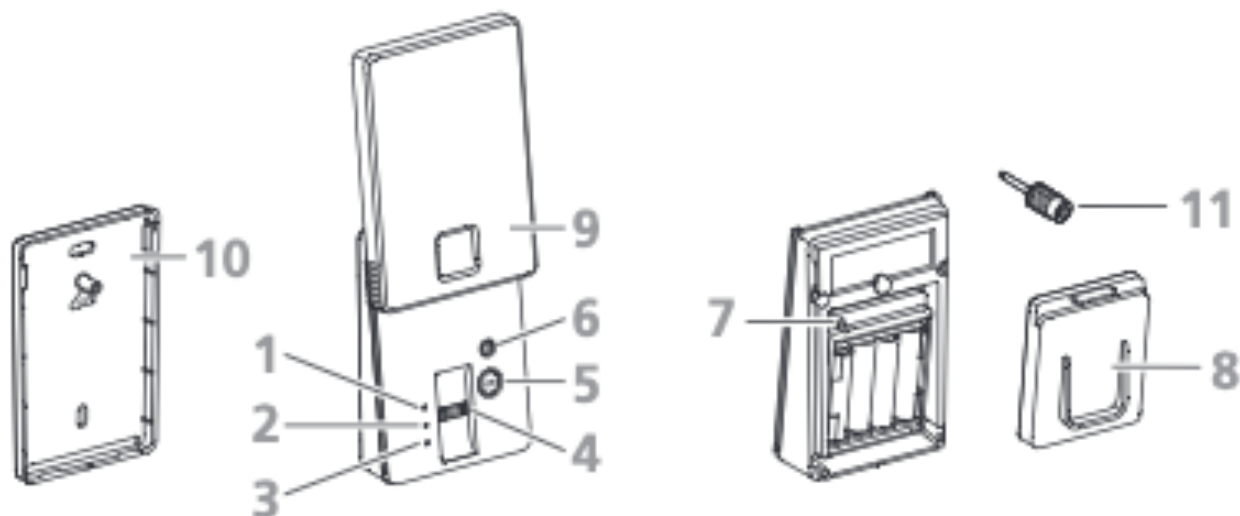

### Legend

- |   |                        |    |   |
|---|------------------------|----|---|
| 1 | LED indicator, red     | 7  | Rear programming button                     |
| 2 | LED indicator, yellow  | 8  | Battery compartment cover                   |
| 3 | LED indicator, green   | 9  | Lid   |
| 4 | Reader module          | 10 | Wall mounting                               |
| 5 | Power button (ON)      | 11 | Programming pin for rear programming button |
| 6 | Programming button (P) |    |   |

## 2.4 LED indicators



LED off



LED flashes slowly



LED illuminated



LED flashes quickly



LED flickers







LED flashes twice and quickly

### 3. Setting in operation

- 2 master fingers allow access to the programming functions.
- 20 user fingers can be programmed in, distributed across 2 radio channels (A and B). Each radio channel can control one opener function or one opener.





#### 3.1 Programming the master fingers

- Only necessary before initial operation or after a reset.
- Two different master fingers must be programmed in to successfully complete programming.
- Different fingers must be used for the master and user fingers.

<p>1.</p>	<ul style="list-style-type: none"> <li>• Slide the lid upwards or press the power button (ON).</li> <li>- No master finger programmed.</li> </ul>		<p><b>20 s</b></p>
<p>2.</p>	<ul style="list-style-type: none"> <li>• Swipe the new master finger 1 fully across the reader module.</li> </ul>		<p><b>2 s</b></p>
<p>3.</p>	<ul style="list-style-type: none"> <li>- No master finger 2 programmed.</li> </ul>		<p><b>20 s</b></p>
<p>4.</p>	<ul style="list-style-type: none"> <li>• Swipe the new master finger 2 fully across the reader module.</li> </ul>		<p><b>2 s</b></p>
<p>5.</p>	<ul style="list-style-type: none"> <li>- The devices switches to "ready for operation" mode.</li> </ul>		<p><b>20 s</b></p>



### 3.2 Programming the user fingers



























- User fingers must not already be used as master fingers. This is a safeguard to maintain proper working order at all times.
- If the memory is full (20 user fingers), then a warning message appears.
- Delete one of the existing user fingers and program in the new finger again, or
- program the new finger in again without deleting anything beforehand. The new user finger will be saved and will replace the first programmed user finger. Each new finger programmed in will then overwrite the second, third, fourth, etc.

1.	<ul style="list-style-type: none"> <li>• Slide the lid upwards or press the power button (ON).</li> <li>– The devices switches to "ready for operation" mode.</li> </ul>		20 s
2.	<ul style="list-style-type: none"> <li>• Hold the programming button (P) pressed for 4 seconds.</li> </ul>		20 s 20 s
3.	<ul style="list-style-type: none"> <li>• Swipe a valid master finger fully across the reader module.</li> </ul>		20 s 20 s 2 s
4.	Radio channel A		20 s 20 s
5.	<p>Radio channel A:</p> <ul style="list-style-type: none"> <li>• Swipe a new user finger fully across the reader module.</li> <li>– Further user fingers can be programmed in one after the other. Repeat step 5 until all of the user fingers for radio channel A have been programmed in.</li> </ul>		20 s 20 s 2 s

**Possible errors**

- User finger or unknown finger scanned; programming mode ends immediately.
- Carry out the steps again.
  
- Memory full; programming mode ends immediately.
- Delete a user finger that is no longer needed and carry out the steps again, or
- while the yellow LED is still illuminated, carry out the steps again in order to overwrite an existing finger. To overwrite several fingers, this process must be started again each time.

	
	<b>20 s</b>
	
	<b>20 s</b>
	<b>20 s</b>
	<b>4 s</b>

<p><b>6.</b> Switch to radio channel B (optional):</p> <ul style="list-style-type: none"> <li>• Press the programming button (P).</li> </ul>	<table border="0"> <tr> <td></td> <td><b>20 s</b></td> </tr> <tr> <td></td> <td><b>20 s</b></td> </tr> <tr> <td></td> <td></td> </tr> </table>		<b>20 s</b>		<b>20 s</b>		
	<b>20 s</b>						
	<b>20 s</b>						
							
<p>Radio channel B:</p> <ul style="list-style-type: none"> <li>• Swipe a new user finger fully across the reader module.</li> <li>– Further user fingers can be programmed in one after the other. Repeat step 7 until all of the user fingers for radio channel B have been programmed in.</li> </ul>	<table border="0"> <tr> <td></td> <td><b>20 s</b></td> </tr> <tr> <td></td> <td><b>20 s</b></td> </tr> <tr> <td></td> <td><b>2 s</b></td> </tr> </table>		<b>20 s</b>		<b>20 s</b>		<b>2 s</b>
	<b>20 s</b>						
	<b>20 s</b>						
	<b>2 s</b>						
<p><b>Possible errors</b></p> <ul style="list-style-type: none"> <li>• see point 5</li> </ul>							
<p><b>8.</b> Either wait until the red LED switches off, or hold the programming button (P) pressed for 4 seconds.</p>	<table border="0"> <tr> <td></td> <td></td> </tr> <tr> <td></td> <td><b>20 s</b></td> </tr> <tr> <td></td> <td></td> </tr> </table>				<b>20 s</b>		
							
	<b>20 s</b>						
							

### 3.3 Programming the device

- The device has two radio channels (A and B) at its disposal. The relevant radio channel is programmed in the opener or control unit via a user finger that has been programmed into the device.

- Remove the device from the wall.
  - Remove the battery compartment cover.

- Set the opener, control unit or receiver to radio teach-in mode. The radio symbol  flashes on the opener/control unit.



Follow the instructions indicated in the documentation supplied with the opener or receiver.

- Slide the lid upwards or press the power button (ON).
  - The devices switches to "ready for operation" mode.



- Press the rear programming button.



- Swipe a valid master finger fully across the reader module.







#### Possible errors

- User finger or unknown finger scanned; programming mode ends immediately.
- Carry out the steps again.





6.	<ul style="list-style-type: none"> <li>• Swipe a valid user finger fully across the reader module.</li> <li>– A programming telegram is transmitted.</li> </ul>	 <b>20 s</b> <b>2 s</b>
<b>Possible errors</b>		 <b>2 s</b>
7.	– Device reverts to user mode.	 <b>20 s</b>
8.	End the radio teach-in mode on the opener, control or receiver. The radio symbol  goes off on the opener/control unit.	
		Follow the instructions indicated in the documentation supplied with the opener of receiver.
9.	– In order to program radio channel B, carry out the steps again and scan the user fingers for radio channel B.	
10.	<ul style="list-style-type: none"> <li>• Replace the battery compartment cover.</li> <li>• Mount the device on the wall.</li> </ul>	

## 4. Operation

### 4.1 Actuating the function

1.	<ul style="list-style-type: none"> <li>• Slide the lid upwards or press the power button (ON).</li> <li>– Device reverts to user mode.</li> </ul>	 <b>20 s</b>
----	---	--

- 2.
- Swipe a valid user finger fully across the reader module.
  - If the indicator flashes 10 times, replace the batteries.



1 x



10 x

**Possible errors**

- Unknown finger.
- Master finger scanned.



2 s

**4.2 Deleting user fingers**

- 1.
- Slide the lid upwards or press the power button (ON).
  - The device switches to "ready for operation" mode.



20 s

- 2.
- Hold the programming button (P) pressed for 4 seconds.

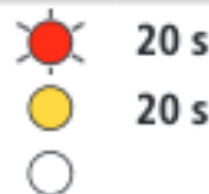

20 s

20 s

- 3.
- Hold the programming button (P) pressed for 4 seconds.



20 s

20 s

- 4.
- Swipe a valid master finger fully across the reader module.

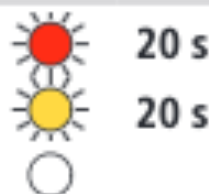

20 s









20 s

**Possible errors**

- Unknown finger scanned; programming mode ends immediately.









2 s

5.	<b>Delete a single user finger</b> <ul style="list-style-type: none"> <li>• Swipe the user finger to be deleted fully across the reader module.</li> </ul>		20 s
			20 s
			2 s
	<b>Delete all of the user fingers</b> <ul style="list-style-type: none"> <li>• Press the programming button (P).</li> </ul>		20 s
			20 s
			> 2 s
6.	– Device reverts to user mode or operational mode.		
			20 s
			

### 4.3 Reset

– All of the master and user fingers will be deleted and new radio codes will be generated.

1.	<ul style="list-style-type: none"> <li>• Remove the device from the wall.</li> <li>• Remove the battery compartment cover.</li> <li>• Slide up the lid.</li> <li>• Take out a battery.</li> </ul>		
2.	<ul style="list-style-type: none"> <li>• Replace the battery while holding the rear programming button pressed.</li> <li>• Release the rear programming button.</li> </ul>		
			
			
3.	<ul style="list-style-type: none"> <li>– Device is reset to factory settings.</li> <li>– No master finger programmed. Program new master finger.</li> </ul>		20 s
			
			

## 4.4 Changing the batteries

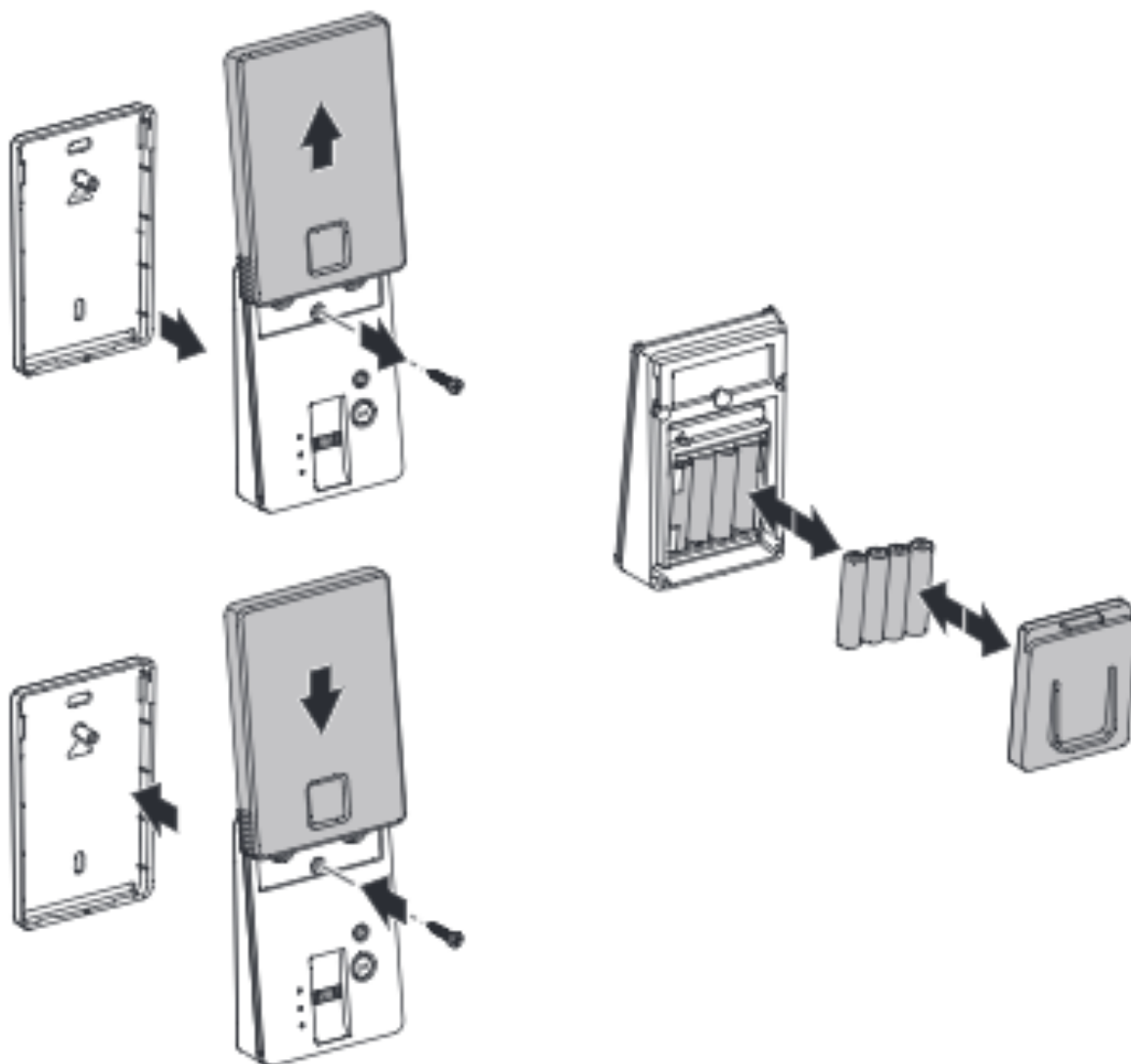

Do not dispose of old equipment or batteries with the normal household waste!



## 5. Assignment

A table is provided at the end of this manual for noting the names of the master fingers and user fingers.

## 6. Technical data



AAA, 1.5V



°C

-20



°C

+60



IP54



868,3 MHz (max. 0,15 mW)  
433,92 MHz (max. 0,13 mW)

## F Instructions de service



### 1. À propos de ce produit

- Notice originale.
- Partie du produit.
- A lire et conserver obligatoirement.
- Tous droits d'auteur réservés.
- Toute reproduction, même partielle, est interdite sans notre autorisation.
- Sous réserve de modifications servant au progrès technique.
- Les illustrations ne correspondent pas exactement aux dimensions.

#### Déclaration UE de conformité simplifiée

Le soussigné, Marantec Antriebs- und Steuerungstechnik GmbH & Co. KG, déclare que l'équipement radioélectrique du type Digital 528 est conforme à la directive 2014/53/UE. Le texte complet de la déclaration UE de conformité est disponible à l'adresse internet suivante: [www.marantec.com](http://www.marantec.com)



#### AVERTISSEMENT !

##### Risque de blessure par un actionnement incontrôlé de la porte !

- Actionnez la commande ou l'émetteur portable uniquement si personne ni aucun objet ne se trouve dans la zone de mouvement de la porte.
- Assurez-vous que ni la commande ni l'émetteur portable n'est utilisé par des enfants ou des personnes non autorisées.
- Assurez-vous que l'émetteur portable n'est pas actionné involontairement (par ex. dans la poche du pantalon).



#### RÉFÉRENCE

La documentation de l'opérateur ou du récepteur doit être observée.

Veuillez consulter la section FAQ sur la page internet suivante pour obtenir des informations utiles ainsi qu'un tutoriel vidéo pour la configuration de l'appareil : [www.marantec.com](http://www.marantec.com)



## 2. Présentation du produit

### 2.1 Contenu de la livraison

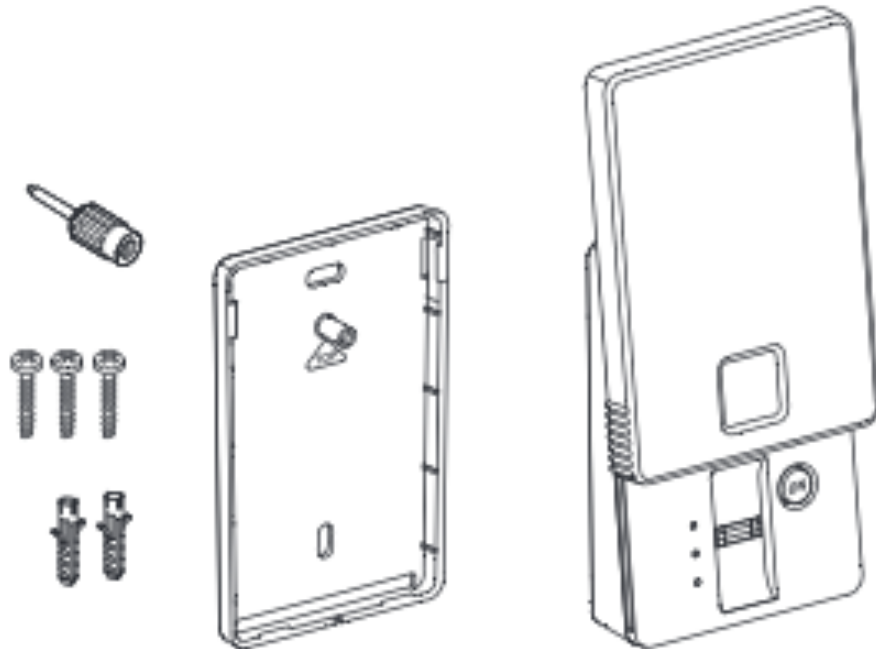

### 2.2 Montage

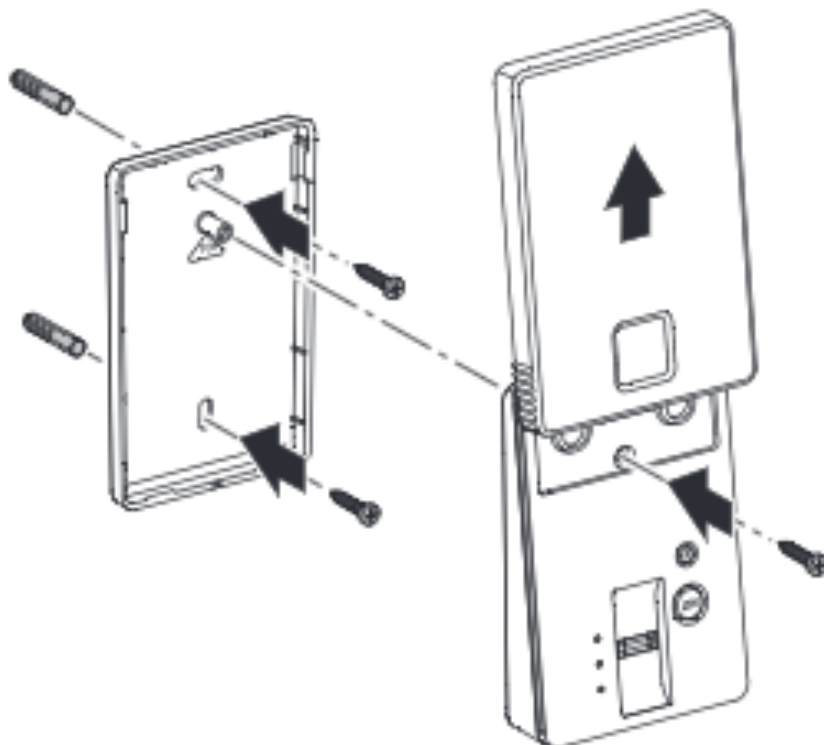

## 2.3 Aperçu

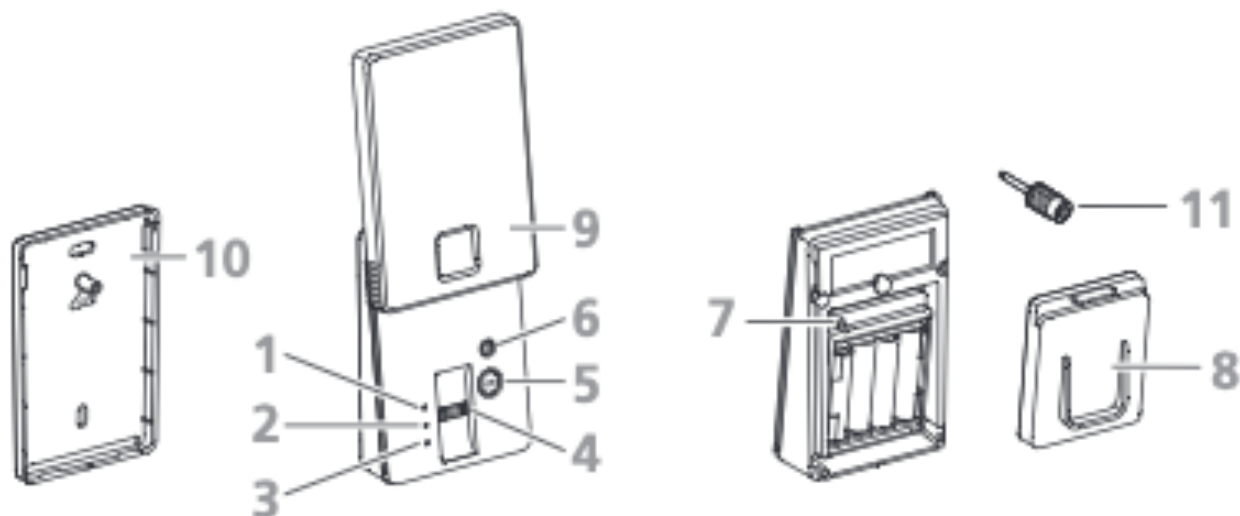

### Légende

- |   |                                 |    |  |
|---|---------------------------------|----|--|
| 1 | Affichage DEL rouge             | 8  | Couvercle du compartiment à piles                                |
| 2 | Affichage DEL jaune             | 9  | Cache  |
| 3 | Affichage DEL verte             | 10 | Support mural  |
| 4 | Module de lecture               | 11 | Styilet de programmation pour la touche de programmation arrière |
| 5 | Touche Power (ON)               |    |  |
| 6 | Touche de programmation (P)     |    |  |
| 7 | Touche de programmation arrière |    |  |

## 2.4 Affichage DEL



DEL éteinte



DEL clignote lentement



DEL allumée



DEL clignote rapidement

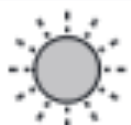

DEL vacille

















DEL clignote deux fois et rapidement

### 3. Mise en service

- 2 empreintes digitales maîtres garantissent l'accès aux fonctions de programmation.
- 20 empreintes digitales d'utilisateur peuvent être apprises, réparties sur 2 canaux radios (A + B). Chaque canal radio peut commander une fonction de motorisation ou un moteur.















#### 3.1 Apprentissage de l'empreinte digitale maître

- Seulement nécessaire à la mise en service ou après une réinitialisation.
- Il est nécessaire d'apprendre 2 empreintes digitales maîtres différentes afin de terminer la programmation avec succès.
- Les empreintes digitales maîtres et les empreintes digitales d'utilisateur doivent être différentes.

<p>1.</p>	<ul style="list-style-type: none"> <li>• Faire glisser le cache ou appuyer sur la touche Power (ON).</li> <li>- Aucune empreinte digitale maître apprise.</li> </ul>	  	<p><b>20 s</b></p>
<p>2.</p>	<ul style="list-style-type: none"> <li>• Passer la nouvelle empreinte digitale maître 1 entièrement sur le module de lecture.</li> </ul>	  	<p><b>2 s</b></p>
<p>3.</p>	<ul style="list-style-type: none"> <li>- Aucune empreinte digitale maître 2 apprise.</li> </ul>	  	<p><b>20 s</b></p>
<p>4.</p>	<ul style="list-style-type: none"> <li>• Passer la nouvelle empreinte digitale maître 2 entièrement sur le module de lecture.</li> </ul>	  	<p><b>2 s</b></p>
<p>5.</p>	<ul style="list-style-type: none"> <li>- L'appareil passe en attente de fonctionnement.</li> </ul>	  	<p><b>20 s</b></p>

### 3.2 Apprentissage des empreintes digitales d'utilisateur

- Une empreinte digitale d'utilisateur ne doit pas être déjà utilisée en tant qu'empreinte digitale maître afin de garantir un fonctionnement correct et durable.
- Si la mémoire est pleine (20 empreintes digitales d'utilisateur) un message d'avertissement s'affiche.
- Supprimer une empreinte digitale existante et effectuer l'apprentissage une nouvelle fois, ou
- effectuer l'apprentissage une nouvelle fois sans suppression au préalable. La nouvelle empreinte digitale d'utilisateur est enregistrée et remplace la 1ère empreinte digitale apprise. Chaque autre empreinte digitale apprise écrase la 2è, 3è, 4è etc..

1.	<ul style="list-style-type: none"> <li>• Faire glisser entièrement le cache ou appuyer sur la touche Power (ON).</li> <li>– L'appareil passe en attente de fonctionnement.</li> </ul>	  	20 s
2.	<ul style="list-style-type: none"> <li>• Maintenir enfoncée la touche de programmation (P) pendant 4 secondes.</li> </ul>	  	20 s 20 s
3.	<ul style="list-style-type: none"> <li>• Passer les empreintes digitales maîtres valides entièrement sur le module de lecture.</li> </ul>	  	20 s 20 s 2 s
4.	Canal radio A	  	20 s 20 s
5.	<p>Canal radio A :</p> <ul style="list-style-type: none"> <li>• Passer la nouvelle empreinte digitale d'utilisateur entièrement sur le module de lecture.</li> <li>– D'autres empreintes digitales d'utilisateur peuvent être apprises les unes après les autres. Répéter l'étape 5 jusqu'à ce que les empreintes digitales d'utilisateur pour le canal radio A soient</li> </ul>	  	20 s 20 s 2 s

**Erreurs possibles**

- Lecture d’une empreinte digitale d’utilisateur ou d’une empreinte digitale inconnue, le mode de programmation s’arrête immédiatement.
- Effectuer les étapes une nouvelle fois.
- Mémoire pleine, le mode de programmation s’arrête immédiatement.
- Supprimer les empreintes digitales d’utilisateur inutilisées et effectuer les étapes une nouvelle fois ou
- Effectuer les étapes une nouvelle fois tant que la DEL jaune est encore allumée pour écraser une empreinte digitale existante. Pour écraser plusieurs empreintes digitales, cette procédure doit être recommencée à chaque fois.

○  
● 20 s  
○  
● 20 s  
● 4 s

**6.** Passage au canal radio B (en option) :

- Appuyer sur la touche de programmation (P).

● 20 s  
● 20 s  
○

**7.** Canal radio B :

- Passer la nouvelle empreinte digitale d’utilisateur entièrement sur le module de lecture.
- D’autres empreintes digitales d’utilisateur peuvent être apprises les unes après les autres. Répéter l’étape 7 jusqu’à ce que les empreintes digitales d’utilisateur pour le canal radio B soient apprises.

● 20 s  
● 20 s  
● 2 s

**Erreurs possibles**

- voir point 5

**8.**

- Attendre jusqu’à ce que la DEL rouge s’éteigne ou maintenir enfoncée la touche de programmation (P) pendant 4 secondes.
- L’appareil passe en attente de fonctionnement.

○  
● 20 s  
○



### 3.3 Apprentissage de l'appareil

- L'appareil dispose de deux canaux radio (A + B). À l'aide d'une empreinte digitale apprise dans l'appareil, le canal radio correspondant dans la motorisation ou la commande peut faire l'apprentissage.

1.
  - Déposer l'appareil du mur.
  - Retirer le couvercle du compartiment à piles.

Mettre l'opérateur, la commande ou le récepteur en mode programmation par signal radio.

2.
  - Le symbole radio clignote sur l'opérateur/la commande .



La documentation de l'opérateur ou du récepteur doit être observée.

3.
  - Faire glisser le cache ou appuyer sur la touche Power (ON).
  - L'appareil passe en attente de fonctionnement



4.
  - Appuyer sur la touche de programmation arrière.



5.
  - Passer les empreintes digitales maîtres valides entièrement sur le module de lecture.







#### Erreurs possibles

- Lecture d'une empreinte digitale d'utilisateur ou d'une empreinte digitale inconnue, le mode de programmation s'arrête immédiatement.
- Effectuer les étapes une nouvelle fois.





6.	<ul style="list-style-type: none"> <li>• Passer l’empreinte digitale d’utilisateur valide entièrement sur le module de lecture.</li> <li>– Un télégramme d’apprentissage est envoyé.</li> </ul>	 <b>20 s</b> <b>2 s</b>
<b>Erreurs possibles</b>		 <b>2 s</b>
7.	– L’appareil passe en attente d’utilisateur.	 <b>20 s</b>
8.	<p>Terminer le mode programmation par signal radio sur l’opérateur, la commande ou le récepteur.</p> <p>Le symbole radio est désactivé sur l’opérateur/la commande .</p>	
		<p>La documentation de l’opérateur ou du récepteur doit être observée.</p>
9.	– Pour l’apprentissage du canal radio B, effectuer les étapes une nouvelle fois et lire les empreintes digitales pour le canal radio B.	
10.	<ul style="list-style-type: none"> <li>• Monter le couvercle du compartiment à piles.</li> <li>• Monter l’appareil au mur.</li> </ul>	

## 4. Utilisation









### 4.1 Déclencher le fonctionnement

1.	<ul style="list-style-type: none"> <li>• Faire glisser le cache ou appuyer sur la touche Power (ON).</li> <li>– L’appareil passe en attente d’utilisateur.</li> </ul>	 <b>20 s</b>
----	---	--

2.	<ul style="list-style-type: none"> <li>• Passer l’empreinte digitale d’utilisateur valide entièrement sur le module de lecture.</li> <li>– Remplacer les piles en cas de 10 clignotements.</li> </ul>		1 x	
			10 x	
	<b>Erreurs possibles</b>		2 s	
	<ul style="list-style-type: none"> <li>– Empreintes digitales inconnues.</li> <li>– Lecture de l’empreinte digitale maître.</li> </ul>			







## 4.2 Suppression des empreintes digitales d'utilisateur

1.	<ul style="list-style-type: none"> <li>• Faire glisser le recouvrement ou actionner la touche Power (ON).</li> <li>– L’appareil passe en attente de fonctionnement.</li> </ul>		20 s	
2.	<ul style="list-style-type: none"> <li>• Maintenir enfoncée la touche de programmation (P) pendant 4 secondes.</li> </ul>		20 s	20 s
3.	<ul style="list-style-type: none"> <li>• Maintenir enfoncée la touche de programmation (P) pendant 4 secondes.</li> </ul>		20 s	20 s
4.	<ul style="list-style-type: none"> <li>• Passer les empreintes digitales maîtres valides entièrement sur le module de lecture.</li> </ul>		20 s	20 s
	<b>Erreurs possibles</b>		2 s	
	<ul style="list-style-type: none"> <li>– Lecture d’une empreinte digitale inconnue, le mode de programmation s’arrête immédiatement.</li> <li>• Effectuer les étapes une nouvelle fois</li> </ul>			

5.	<b>Suppression d'une seule empreinte digitale d'utilisateur</b>		20 s
	<ul style="list-style-type: none"> <li>Passer l'empreinte digitale d'utilisateur à supprimer entièrement sur le module de lecture.</li> </ul>		20 s
			2 s
		<hr/>	
	<b>Suppression de toutes les empreintes digitales d'utilisateur</b>		20 s
	<ul style="list-style-type: none"> <li>Appuyer sur la touche de programmation (P).</li> </ul>		20 s
		> 2 s	
<hr/>			
6.	<ul style="list-style-type: none"> <li>L'appareil passe en attente de fonctionnement ou d'utilisateur.</li> </ul>		
			20 s
			

### 4.3 Réinitialisation

– Toutes les empreintes digitales maîtres et d'utilisateur sont supprimées et de nouveaux codes radios sont générés.

1.	<ul style="list-style-type: none"> <li>Déposer l'appareil du mur.</li> <li>Retirer le couvercle du compartiment à piles.</li> <li>Faire glisser le cache.</li> <li>Retirer une pile.</li> </ul>		
	2.	<ul style="list-style-type: none"> <li>Remettre en place la pile en maintenant la touche de programmation enfoncée.</li> <li>Relâcher la touche de programmation arrière.</li> </ul>	  
		<hr/>	
3.	<ul style="list-style-type: none"> <li>L'appareil est réinitialisé.</li> <li>Aucune empreinte digitale maître apprise.</li> </ul>	  	20 s
	<ul style="list-style-type: none"> <li>Apprendre de nouvelles empreintes digitales maîtres.</li> </ul>		

## 4.4 Remplacer la pile

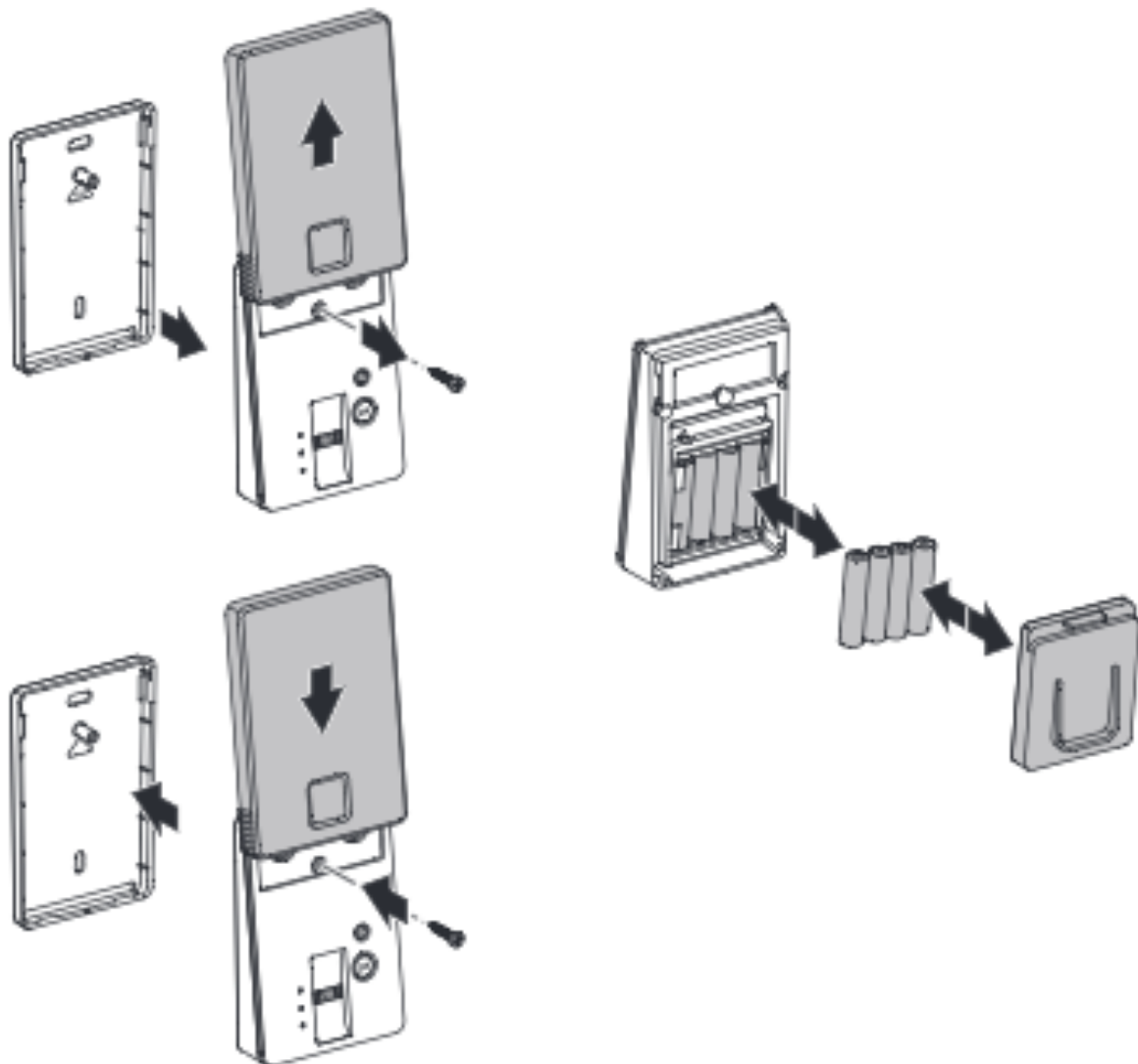

Les appareils usagés et les batteries ne doivent pas être jetés avec les déchets domestiques !



## 5. Attribution

Vous trouverez un tableau permettant d'inscrire les empreintes digitales maîtres et utilisateurs à la fin du document.

## 6. Caractéristiques techniques



AAA, 1,5V



°C

-20



°C

+60



IP54



868,3 MHz (max. 0,15 mW)  
433,92 MHz (max. 0,13 mW)

## E Instrucciones de uso



### 1. Información sobre este producto

- Instrucciones originales.
- Parte del producto.
- Es estrictamente necesario leerlas y conservarlas.
- Protegidas por derechos de autor.
- La reimpresión, incluso parcial, solo está permitida con nuestra autorización.
- Se reserva el derecho de realizar modificaciones que sirvan para el progreso técnico.
- Las representaciones no se reflejan a escala.

#### **Declaración UE de conformidad simplificada**

Por la presente, Marantec Antriebs- und Steuerungstechnik GmbH & Co. KG declara que el tipo de equipo radioeléctrico Digital 528 es conforme con la Directiva 2014/53/UE. El texto completo de la declaración UE de conformidad está disponible en la dirección Internet siguiente: [www.marantec.com](http://www.marantec.com)

### ¡ADVERTENCIA!

#### **¡Riesgo de lesiones por accionamiento incontrolado de la puerta!**

- El mando o el emisor manual solo deben accionarse si no hay ninguna persona ni ningún objeto en la zona de movimientos de la puerta.
- Asegúrese de que el mando y el emisor manual no puedan utilizarse por niños o por personas no autorizadas.
- Asegúrese de que el emisor manual no se accione involuntariamente (p. ej., en el bolsillo del pantalón).

### REFERENCIA

Se ha de respetar la documentación del accionamiento o del receptor. Puede consultar información útil y un vídeo de instrucciones para el ajuste del aparato en la sección de preguntas frecuentes del siguiente sitio web: [www.marantec.com](http://www.marantec.com)



## 2. Sinopsis del producto

### 2.1 Volumen de suministro

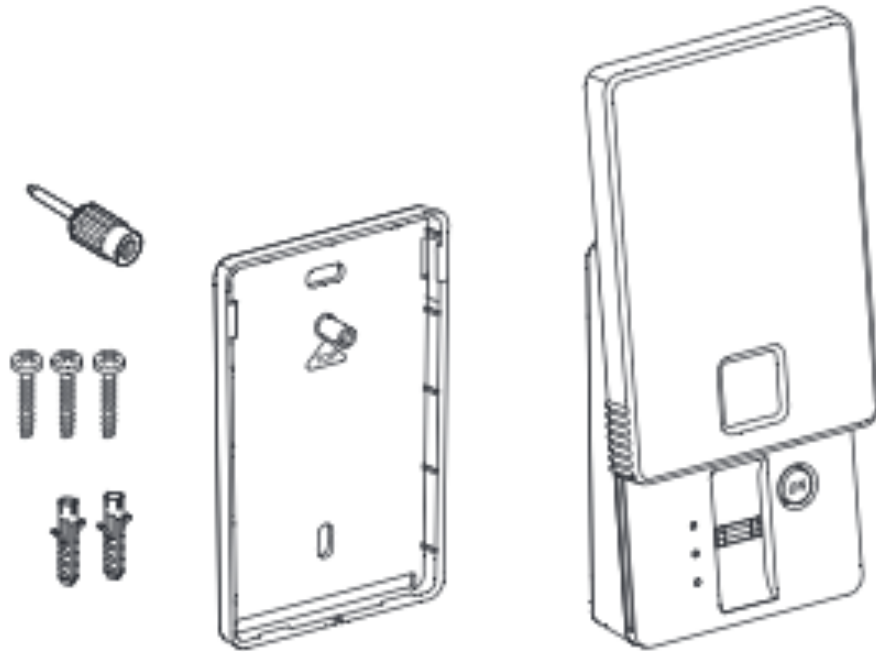

### 2.2 Montaje

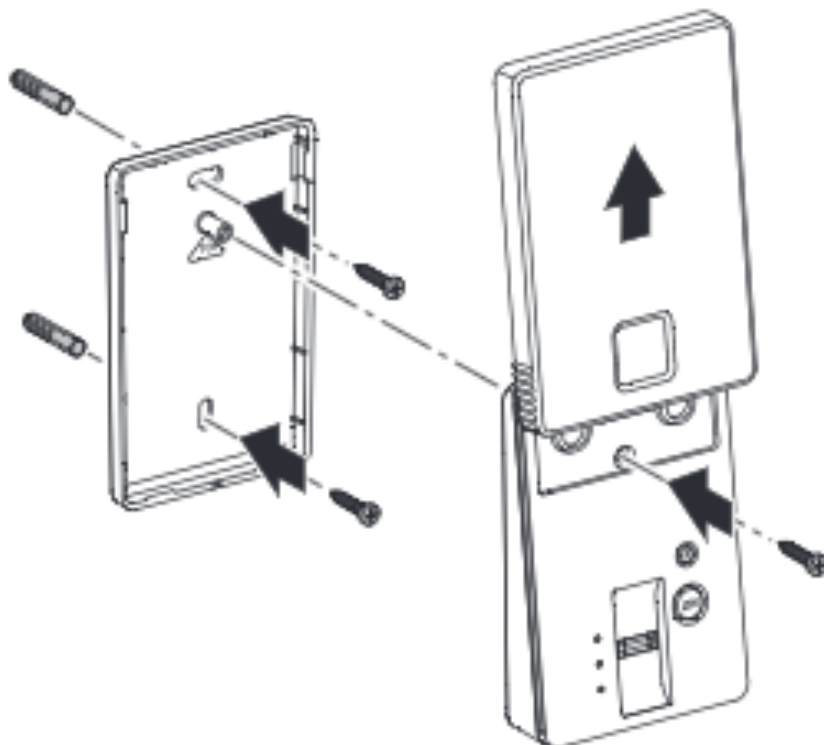

## 2.3 Vista general

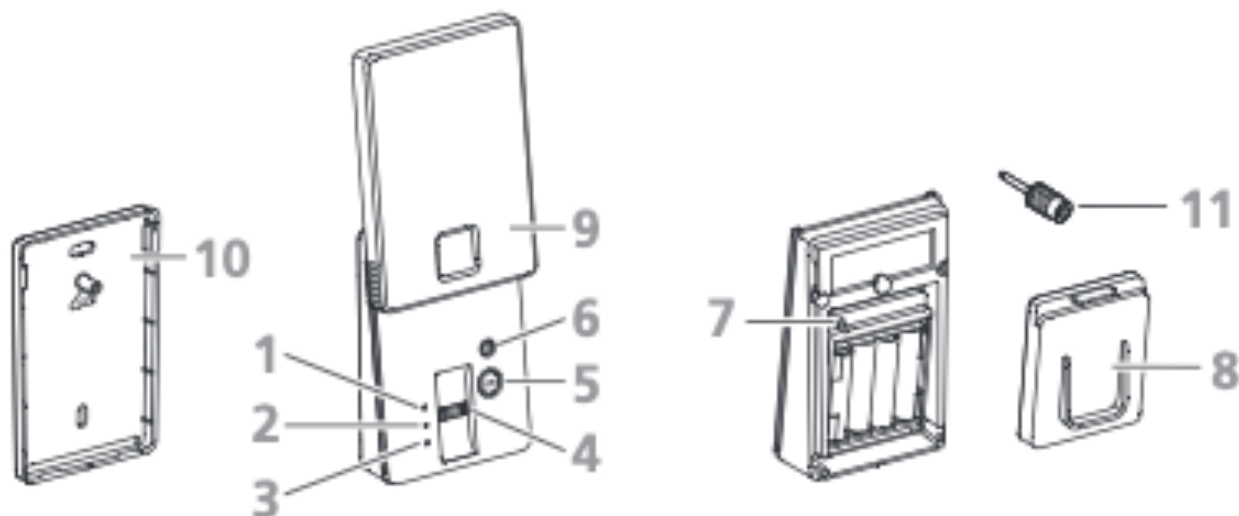

### Leyenda

- |   |                               |    |  |
|---|-------------------------------|----|--|
| 1 | Indicador LED rojo            | 8  | Tapa del compartimento de las pilas                        |
| 2 | Indicador LED amarillo        | 9  | Cubierta   |
| 3 | Indicador LED verde           | 10 | Soporte de pared   |
| 4 | Módulo de lectura             | 11 | Clavija de programación para tecla trasera de programación |
| 5 | Tecla de encendido (ON)       |    |  |
| 6 | Tecla de programación (P)     |    |  |
| 7 | Tecla trasera de programación |    |  |

## 2.4 Indicadores LED



El LED está apagado



El LED parpadea lentamente



El LED está encendido



El LED parpadea rápidamente



El LED centellea

















El LED parpadea dos veces rápidamente

### 3. Puesta en funcionamiento

- 2 huellas maestras permiten acceder a las funciones de programación.
- Es posible programar 20 huellas de usuario distribuidas en 2 canales de radio (A + B). Cada canal de radio puede manejar una función motora o un motor.





#### 3.1 Programar huellas maestras

- Solo es necesario durante la primera puesta en funcionamiento o tras realizar un reset.
- Es preciso programar 2 huellas maestras diferentes para concluir con éxito la programación.
- Las huellas maestras y de usuario deben ser diferentes.

<p>1.</p>	<ul style="list-style-type: none"> <li>• Abrir la cubierta o accionar la tecla de encendido (ON).</li> <li>- No hay ninguna huella maestra programada.</li> </ul>	  	<p>20 s</p>
<p>2.</p>	<ul style="list-style-type: none"> <li>• Colocar el dedo con la nueva huella maestra 1 cubriendo completamente el módulo de lectura.</li> </ul>	  	<p>2 s</p>
<p>3.</p>	<ul style="list-style-type: none"> <li>- No hay ninguna huella maestra 2 programada.</li> </ul>	  	<p>20 s</p>
<p>4.</p>	<ul style="list-style-type: none"> <li>• Colocar el dedo con la nueva huella maestra 2 cubriendo completamente el módulo de lectura.</li> </ul>	  	<p>2 s</p>
<p>5.</p>	<ul style="list-style-type: none"> <li>- El equipo cambia al modo operativo.</li> </ul>	  	<p>20 s</p>

### 3.2 Programar huellas de usuario

- Una huella de usuario no puede utilizarse ya como huella maestra para garantizar un funcionamiento correcto y permanente.
- Si la memoria está llena (20 huellas de usuario), aparece un mensaje de advertencia.
- Borrar una huella de usuario existente y realizar de nuevo la programación o
- realizar de nuevo la programación sin borrar la huella previamente. La nueva huella de usuario se memoriza y sustituye a la 1.ª huella de usuario programada. Cada huella de usuario que se programe a continuación, sobrescribirá la 2.ª, 3.ª, 4.ª huella, etc.

1.	<ul style="list-style-type: none"> <li>• Abrir la cubierta por completo o accionar la tecla de encendido (ON).</li> <li>– El equipo cambia al modo operativo.</li> </ul>		20 s
2.	<ul style="list-style-type: none"> <li>• Mantener pulsada la tecla de programación (P) durante 4 segundos.</li> </ul>		20 s 20 s
3.	<ul style="list-style-type: none"> <li>• Colocar el dedo con la huella maestra válida cubriendo completamente el módulo de lectura.</li> </ul>		20 s 20 s 2 s
4.	Canal de radio A		20 s 20 s
5.	<p>Canal de radio A:</p> <ul style="list-style-type: none"> <li>• Colocar el dedo con la nueva huella de usuario cubriendo completamente el módulo de lectura.</li> <li>– Es posible programar consecutivamente más huellas de usuario. Repetir el paso 5 tantas veces como sea necesario hasta programar todas las huellas de usuario para el canal de radio A.</li> </ul>		20 s 20 s 2 s

**Posibles errores**

- Huella de usuario o huella desconocida leída, el modo de programación finaliza de inmediato.
- Ejecutar los pasos de nuevo.
- Memoria llena, el modo de programación finaliza de inmediato.
- Borrar las huellas de usuario que no sean necesarias y repetir los pasos o
- Mientras el LED amarillo continúa encendido, repetir los pasos para sobrescribir una huella memorizada. Para sobrescribir varias huellas, comenzar de nuevo el proceso cada vez.



<b>6.</b>	Cambio al canal de radio B (opcional):		<b>20 s</b>
	• Pulsar la tecla de programación (P).		<b>20 s</b>

<b>7.</b>	Canal de radio B:		
	• Colocar el dedo con la nueva huella de usuario cubriendo completamente el módulo de lectura.		<b>20 s</b>
	– Es posible programar consecutivamente más huellas de usuario. Repetir el paso 7 tantas veces como sea necesario hasta programar todas las huellas de usuario para el canal de radio B.		<b>20 s</b>
			<b>2 s</b>

**Posibles errores**

- Véase el punto 5
- Esperar hasta que el LED rojo se apague o mantener pulsada la tecla de programación (P) durante 4 segundos.
- El equipo cambia a la disponibilidad operativa.





### 3.3 Programar el equipo

- El equipo dispone de dos canales de radio (A + B). El canal de radio correspondiente se programa en el motor o en el mando a través de una huella de usuario programada en el equipo.

- Desmontar el aparato de la pared.
  - Retirar la tapa del compartimento de las pilas.

Colocar el accionamiento, el mando o el receptor en el modo de programación de radio. En el accionamiento o el mando parpadea el símbolo de la radio .



Se ha de respetar la documentación del accionamiento o del receptor.

- Abrir la cubierta o accionar la tecla de encendido (ON).
  - El equipo cambia al modo operativo.



- Pulsar la tecla trasera de programación.



- Colocar el dedo con la huella maestra válida cubriendo completamente el módulo de lectura.













#### Posibles errores

- Huella de usuario o huella desconocida leída, el modo de programación finaliza de inmediato.
- Ejecutar los pasos de nuevo.







6.	<ul style="list-style-type: none"> <li>Colocar el dedo con la huella de usuario válida cubriendo completamente el módulo de lectura.</li> <li>Se envía un telegrama de parametrización.</li> </ul>	  	<b>20 s</b>  <b>2 s</b>
<b>Posibles errores</b>			<b>2 s</b>
<ul style="list-style-type: none"> <li>Huella maestra o huella desconocida leída, el modo de programación finaliza de inmediato.</li> <li>Ejecutar los pasos de nuevo.</li> </ul>		 	
7.	<ul style="list-style-type: none"> <li>El equipo cambia a la disponibilidad de usuario.</li> </ul>	  	<b>20 s</b>
8.	Finalizar el modo de programación de radio en el accionamiento, el mando o el receptor. En el accionamiento o el mando se apaga el símbolo de la radio  .		
		Se ha de respetar la documentación del accionamiento o del receptor.	
9.	<ul style="list-style-type: none"> <li>Para programar el canal de radio B, realizar de nuevo los pasos y leer las huellas de usuario para el canal de radio B.</li> </ul>		
10.	<ul style="list-style-type: none"> <li>Montar la tapa del compartimento de las pilas.</li> <li>Montar el equipo en la pared.</li> </ul>		

## 4. Manejo









### 4.1 Activar una función

1.	<ul style="list-style-type: none"> <li>Abrir la cubierta o accionar la tecla de encendido (ON).</li> <li>El equipo cambia a la disponibilidad de usuario.</li> </ul>	  	<b>20 s</b>
----	--	---	-------------







2.	<ul style="list-style-type: none"> <li>Colocar el dedo con la huella de usuario válida cubriendo completamente el módulo de lectura.</li> <li>Al parpadear 10 veces, cambiar las pilas.</li> </ul>		1 x	
			10 x	
	<b>Posibles errores</b>		2 s	
	<ul style="list-style-type: none"> <li>Huella desconocida.</li> <li>Huella maestra leída.</li> </ul>			

## 4.2 Borrar huellas de usuario

1.	<ul style="list-style-type: none"> <li>Abrir la cubierta o accionar la tecla de encendido (ON).</li> <li>El equipo cambia al modo operativo.</li> </ul>		20 s	
2.	<ul style="list-style-type: none"> <li>Mantener pulsada la tecla de programación (P) durante 4 segundos.</li> </ul>		20 s	
			20 s	
3.	<ul style="list-style-type: none"> <li>Mantener pulsada la tecla de programación (P) durante 4 segundos.</li> </ul>		20 s	
			20 s	
4.	<ul style="list-style-type: none"> <li>Colocar el dedo con la huella maestra válida cubriendo completamente el módulo de lectura.</li> </ul>		20 s	
			20 s	
	<b>Posibles errores</b>		2 s	
	<ul style="list-style-type: none"> <li>Huella desconocida leída, el modo de programación finaliza de inmediato.</li> <li>Ejecutar los pasos de nuevo.</li> </ul>			

5.	<b>Borrar huellas de usuario individualmente</b> <ul style="list-style-type: none"> <li>Colocar el dedo con la huella de usuario que se desee borrar cubriendo completamente el módulo de lectura.</li> </ul>	 20 s  20 s  2 s
	<b>Borrar todas las huellas de usuario</b> <ul style="list-style-type: none"> <li>Pulsar la tecla de programación (P).</li> </ul>	 20 s  20 s  > 2 s
6.	– El equipo cambia a la disponibilidad de usuario u operativa.	  20 s 

### 4.3 Reset

	– Se borran todas las huellas maestras y de usuario y se generan nuevos códigos de radio.	
1.	<ul style="list-style-type: none"> <li>Desmontar el aparato de la pared.</li> <li>Retirar la tapa del compartimento de las pilas.</li> <li>Abrir la cubierta.</li> <li>Extraer una pila.</li> </ul>	
2.	<ul style="list-style-type: none"> <li>Colocar la pila de nuevo manteniendo pulsada la tecla trasera de programación.</li> <li>Soltar la tecla trasera de programación.</li> </ul>	  
3.	– El equipo se ha restablecido a los ajustes de fábrica. – No hay ninguna huella maestra programada. Programar huellas maestras nuevas.	 20 s  

## 4.4 Cambiar las pilas

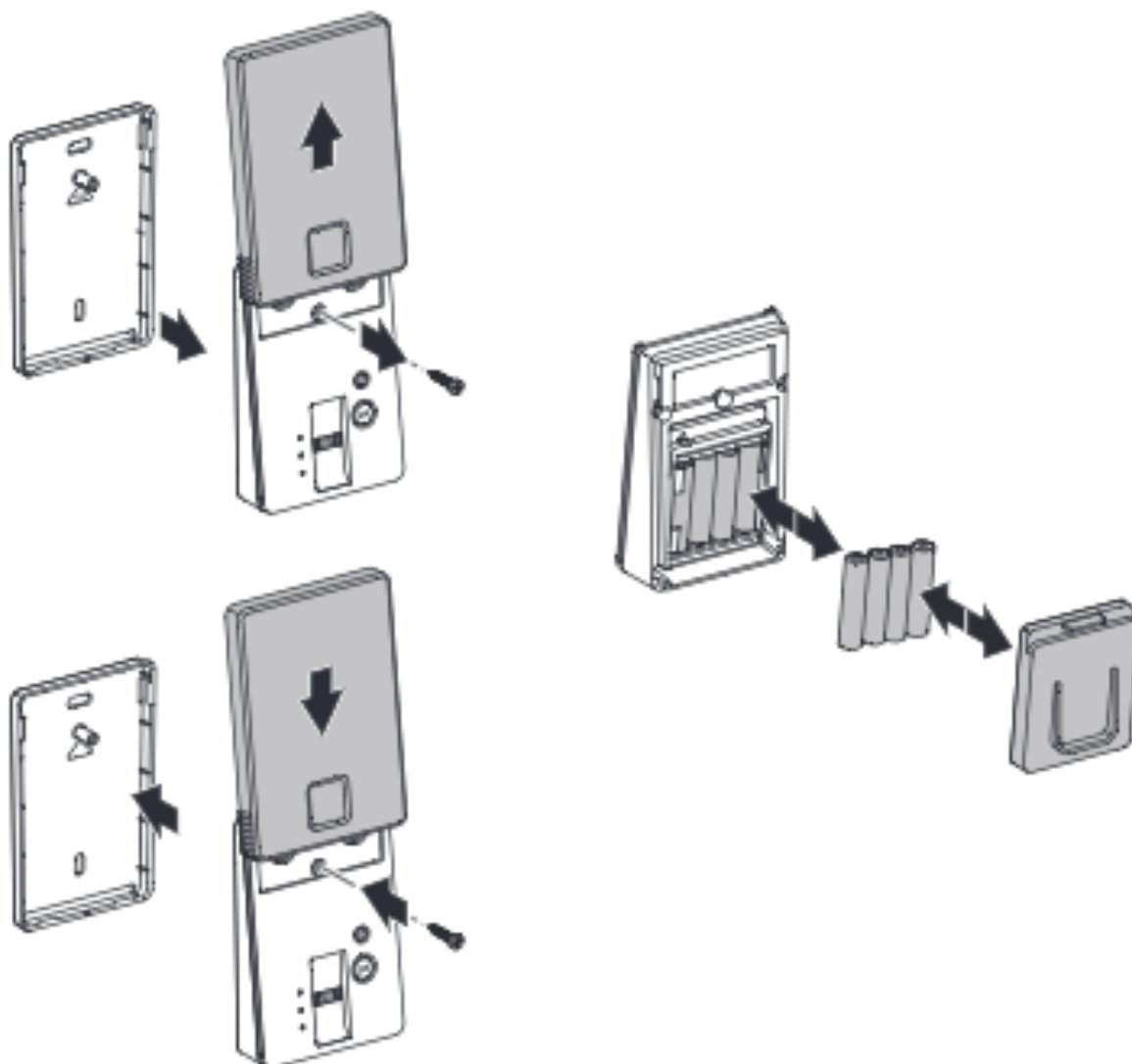

¡Los equipos usados y las pilas no deben eliminarse con la basura doméstica!



## 5. Asignación

Al final del documento hay una tabla para registrar las huellas maestras y de usuario.

## 6. Datos técnicos



AAA, 1,5 V



°C

-20



°C

+60



IP54



868,3 MHz (max. 0,15 mW)  
433,92 MHz (max. 0,13 mW)

# I Istruzioni per l'uso



## 1. Su questo prodotto

- Istruzioni originali.
- Parte del prodotto.
- Leggere e conservare obbligatoriamente.
- Diritti d'autore riservati.
- Ristampa, anche parziale, possibile solo previa nostra autorizzazione.
- Modifiche dovute al progresso tecnico riservate.
- Le dimensioni nelle figure potrebbero non essere fedeli.

### Dichiarazione di conformità UE semplificata

Il fabbricante, Marantec Antriebs- und Steuerungstechnik GmbH & Co. KG, dichiara che il tipo di apparecchiatura radio Digital 528 è conforme alla direttiva 2014/53/UE. Il testo completo della dichiarazione di conformità UE è disponibile al seguente indirizzo Internet: [www.marantec.com](http://www.marantec.com)



## ATTENZIONE!

### Pericolo di lesioni in seguito ad uno spostamento incontrollato del cancello!

- Azionare il comando o il trasmettitore solo se nell'area di spostamento del cancello non sono presenti persone o oggetti.
- Accertarsi che il comando e il trasmettitore non vengano utilizzati da bambini o da persone non autorizzate.
- Accertarsi che il trasmettitore non venga azionato involontariamente (ad es. nella tasca dei pantaloni).



## RIMANDO

Rispettare la documentazione dell'automazione o del ricevitore.  
Le informazioni utili e un video di istruzioni sull'installazione del dispositivo sono disponibili nell'area FAQ del seguente sito web:  
[www.marantec.com](http://www.marantec.com)



## 2. Panoramica del prodotto

### 2.1 Dotazione

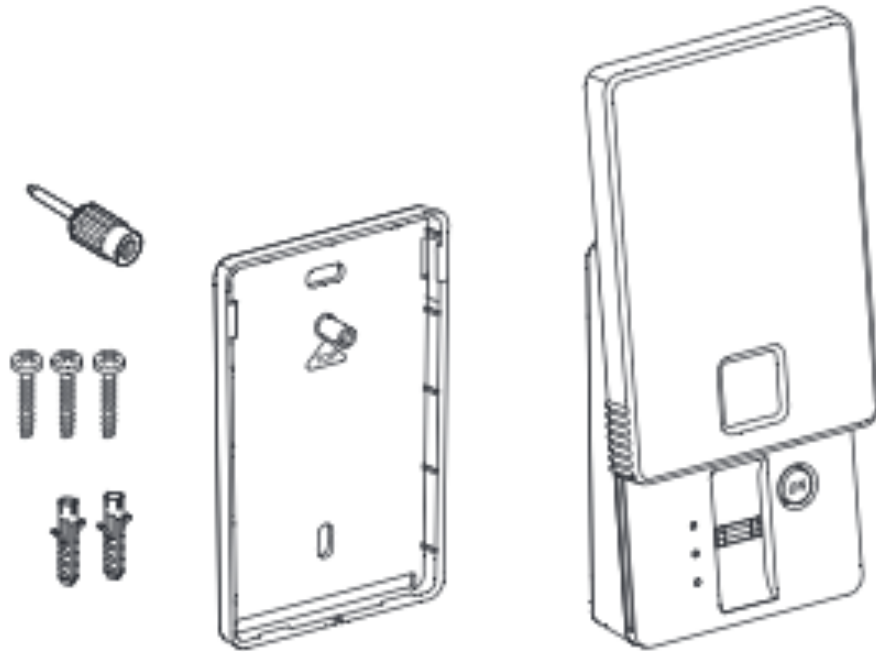

### 2.2 Montaggio

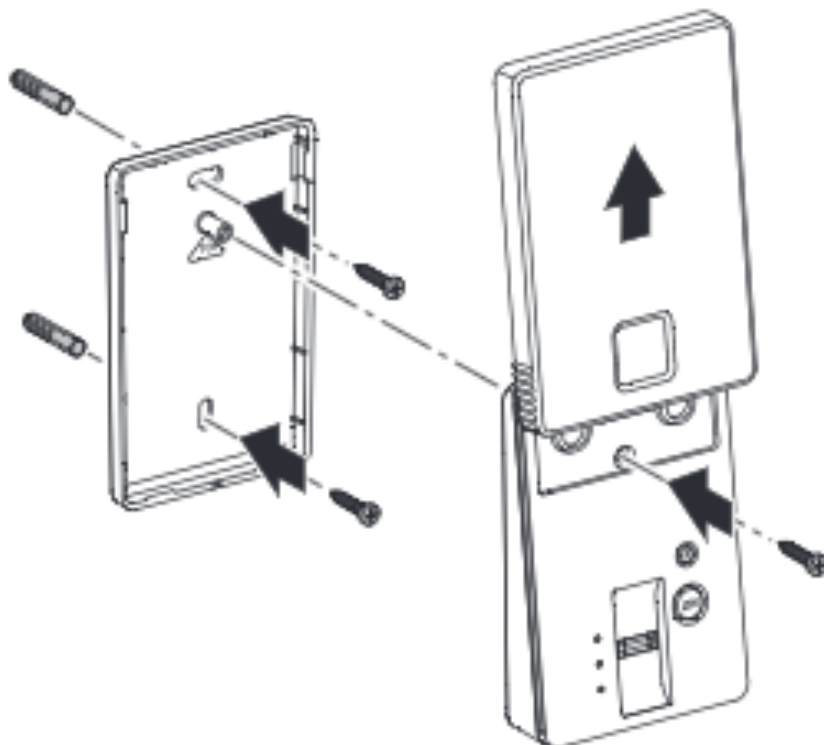

## 2.3 Panoramica

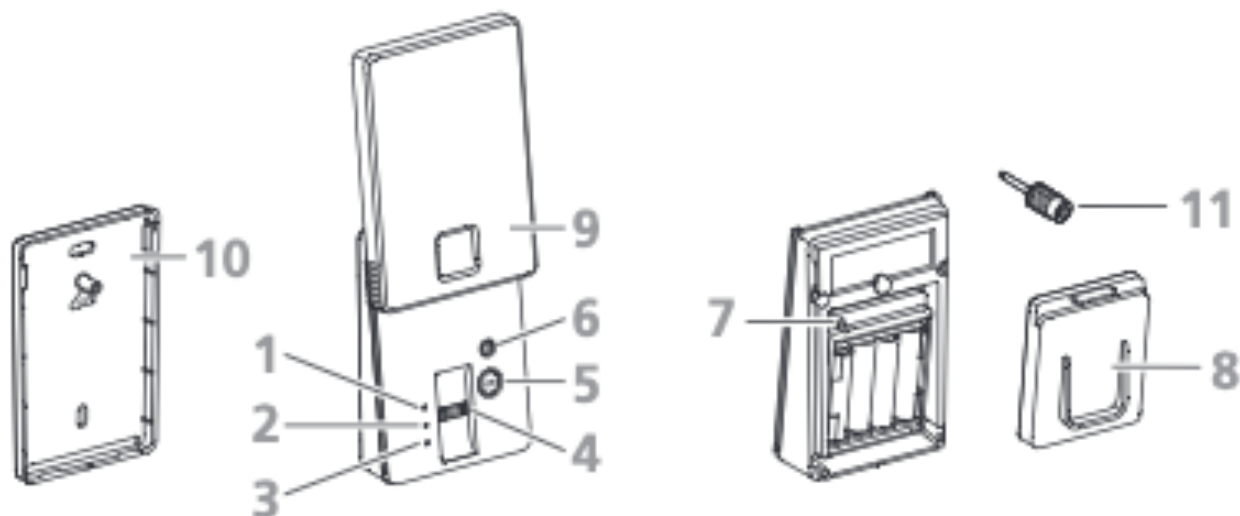

### Legenda

- |   |                             |    |  |
|---|-----------------------------|----|--|
| 1 | Indicatore LED rosso        | 7  | Tasto di programmazione posteriore                             |
| 2 | Indicatore LED giallo       | 8  | Coperchio vano batterie  |
| 3 | Indicatore LED verde        | 9  | Copertura  |
| 4 | Modulo di lettura           | 10 | Supporto a muro  |
| 5 | Tasto di accensione (ON)    | 11 | Perno di programmazione per tasto di programmazione posteriore |
| 6 | Tasto di programmazione (P) |    |  |

## 2.4 Indicatori LED



LED spento



LED lampeggia lentamente



LED acceso



LED lampeggia velocemente

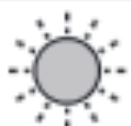

LED fioco







LED lampeggia due volte e rapidamente

### 3. Messa in funzione

- Accesso a 2 dita master alle funzioni di programmazione.
- È possibile registrare 20 dita utente, distribuite su 2 canali radio (A + B).  
Ogni canale radio può avere una funzione di trasmissione o una trasmissione.





#### 3.1 Registrare dita master

- Necessario solo alla prima messa in funzione o dopo un reset.
- Si devono registrare 2 diverse dita master per terminare con successo la programmazione.
- Le dita master e utente devono essere dita diverse.

1.	<ul style="list-style-type: none"> <li>• Spostare la copertura e azionare il tasto di accensione (ON).</li> <li>- Nessun dito master registrato.</li> </ul>		<b>20 s</b>
2.	<ul style="list-style-type: none"> <li>• Passare un nuovo dito master 1 completamente sul modulo di lettura.</li> </ul>		<b>2 s</b>
3.	<ul style="list-style-type: none"> <li>- Nessun dito master 2 registrato.</li> </ul>		<b>20 s</b>
4.	<ul style="list-style-type: none"> <li>• Passare un nuovo dito master 2 completamente sul modulo di lettura.</li> </ul>		<b>2 s</b>
5.	<ul style="list-style-type: none"> <li>- L'apparecchio passa in modalità di pronto per il funzionamento.</li> </ul>		<b>20 s</b>

### 3.2 Registrare le dita utente

- Un dito utente non può essere utilizzato come dito master al fine di garantire un funzionamento corretto e duraturo.
- Se la memoria è piena (20 dita utente) compare un messaggio di avvertimento.
- Cancellare un dito utente presente ed eseguire nuovamente la registrazione oppure
- eseguire nuovamente la registrazione senza cancellazione precedente. Il nuovo dito utente viene memorizzato e sostituisce il 1° dito utente registrato. Ogni altro dito utente registrato sovrascrive il 2°, 3°, 4°, ecc.

1.	<ul style="list-style-type: none"> <li>• Spostare la copertura completamente e azionare il tasto di accensione (ON).</li> <li>– L'apparecchio passa in modalità di pronto per il funzionamento.</li> </ul>		20 s
2.	<ul style="list-style-type: none"> <li>• Tenere il tasto di programmazione (P) premuto per 4 secondi.</li> </ul>		20 s 20 s
3.	<ul style="list-style-type: none"> <li>• Passare un dito master valido completamente sul modulo di lettura.</li> </ul>		20 s 20 s 2 s
4.	Canale radio A		20 s 20 s
5.	<p>Canale radio A:</p> <ul style="list-style-type: none"> <li>• Passare un nuovo dito utente completamente sul modulo di lettura.</li> <li>– È possibile registrare in successione altre dita utente. Ripetere la fase 5 finché non sono state registrate tutte le dita utente per il canale radio A.</li> </ul>		20 s 20 s 2 s

**Possibili errori**

- Registrare dita utente o dita sconosciute, la modalità di programmazione viene terminata immediatamente.
- Eseguire nuovamente i passaggi.
  
- Memoria piena, la modalità di programmazione viene terminata immediatamente.
- Cancellare le dita utente non necessarie ed eseguire nuovamente le fasi oppure
- Eseguire le fasi finché il LED giallo è ancora acceso, al fine di sovrascrivere le dita presenti. Per sovrascrivere più dita, riavviare ogni volta questo processo.



<b>6.</b>	Passaggio al canale radio B (opzionale): <ul style="list-style-type: none"> <li>• Premere il tasto di programmazione (P).</li> </ul>	
-----------	--	--

<b>7.</b>	Canale radio B: <ul style="list-style-type: none"> <li>• Passare un nuovo dito utente completamente sul modulo di lettura.</li> <li>– È possibile registrare in successione altre dita utente. Ripetere la fase 7 finché non sono state registrate tutte le dita utente per il canale radio B.</li> </ul>	
-----------	---	--

**Possibili errori**

- vedere punto 5
  
- Attendere lo spegnimento del LED rosso o tenere premuto per 4 secondi il tasto di programmazione (P).
- L'apparecchio passa in modalità di pronto per il funzionamento.



### 3.3 Registrare l'apparecchio

- L'apparecchio dispone di due canali radio (A + B). Tramite un dito utente registrato nell'apparecchio il canale radio viene registrato nell'automazione o nel comando.

- Smontare l'apparecchio dalla parete.
  - Rimuovere il coperchio del vano batteria.
- Predisporre trasmissione, comando o ricevitori al collegamento radio. Sulla trasmissione/comando lampeggia il simbolo radio .



Osservare la documentazione della trasmissione o del ricevitore.

- Spostare la copertura e azionare il tasto di accensione (ON).
  - L'apparecchio passa in modalità di pronto per il funzionamento.



- Premere il tasto di programmazione posteriore.



- Passare un dito master valido completamente sul modulo di lettura.







#### Possibili errori

- Registrare dita utente o dita sconosciute, la modalità di programmazione viene terminata immediatamente.
- Eseguire nuovamente i passaggi.











6.	<ul style="list-style-type: none"> <li>• Passare un dito utente valido completamente sul modulo di lettura.</li> <li>– Viene inviato un telegramma di riconoscimento.</li> </ul>	 <b>20 s</b> <b>2 s</b>
<b>Possibili errori</b>		 <b>2 s</b>
7.	<ul style="list-style-type: none"> <li>– L'apparecchio passa in modalità di pronto per l'utente.</li> </ul>	 <b>20 s</b>
8.	<p>Terminare la predisposizione all'accoppiamento radio della trasmissione, comando o ricevitore. Sulla trasmissione/comando si spegne il simbolo radio .</p> <p> Osservare la documentazione della trasmissione o del ricevitore.</p>	
9.	<ul style="list-style-type: none"> <li>– Per la registrazione del canale radio B ripetere le fasi e leggere le dita utente per il canale radio B.</li> </ul>	
10.	<ul style="list-style-type: none"> <li>• Montare il coperchio del vano batteria.</li> <li>• Montare l'apparecchio alla parete.</li> </ul>	

## 4. Funzionamento









### 4.1 Attivare funzione

1.	<ul style="list-style-type: none"> <li>• Spostare la copertura e azionare il tasto di accensione (ON).</li> <li>– L'apparecchio passa in modalità di pronto per l'utente.</li> </ul>	 <b>20 s</b>
----	--	--

2.	<ul style="list-style-type: none"> <li>• Passare un dito utente valido completamente sul modulo di lettura.</li> <li>– Cambiare le batterie in caso di 10 x lampeggiamenti.</li> </ul>		1 x	
			10 x	
<b>Possibili errori</b> <ul style="list-style-type: none"> <li>– Dito sconosciuto.</li> <li>– Dito master letto.</li> </ul>			2 s	

#### 4.2 Cancella dito utente

1.	<ul style="list-style-type: none"> <li>• Spostare la copertura e azionare il tasto di accensione (ON).</li> <li>– L'apparecchio passa in modalità di pronto per il funzionamento.</li> </ul>		20 s	
2.	<ul style="list-style-type: none"> <li>• Tenere il tasto di programmazione (P) premuto per 4 secondi.</li> </ul>		20 s 20 s	
3.	<ul style="list-style-type: none"> <li>• Tenere il tasto di programmazione (P) premuto per 4 secondi.</li> </ul>		20 s 20 s	
4.	<ul style="list-style-type: none"> <li>• Passare un dito master valido completamente sul modulo di lettura.</li> </ul>		20 s 20 s	
<b>Possibili errori</b> <ul style="list-style-type: none"> <li>– Dito sconosciuto letto, la modalità di programmazione viene terminata immediatamente.</li> </ul>			2 s	

5.	<b>Cancella singolo dito utente</b> • Passare un dito utente da cancellare completamente sul modulo di lettura.		20 s
			20 s
			2 s
	<b>Cancella tutte le dita utente</b> • Premere il tasto di programmazione (P).		20 s
			20 s
			> 2 s
6.	– L'apparecchio passa in modalità di pronto per l'utente o per il funzionamento.		
			20 s
			

### 4.3 Reset

– Tutte le dita utente e master vengono cancellate e vengono generati nuovi codici radio.

1.
  - Smontare l'apparecchio dalla parete.
  - Rimuovere il coperchio del vano batteria.
  - Applicare la copertura.
  - Rimuovere una batteria.

2.
  - Reinstallare la batteria tenendo premuto il tasto di programmazione posteriore.
  - Rilasciare il tasto di programmazione posteriore.



3.
  - L'apparecchio viene ripristinato alle impostazioni di fabbrica.
  - Nessun dito master registrato. Registrare nuova dita master.



## 4.4 Cambio batteria

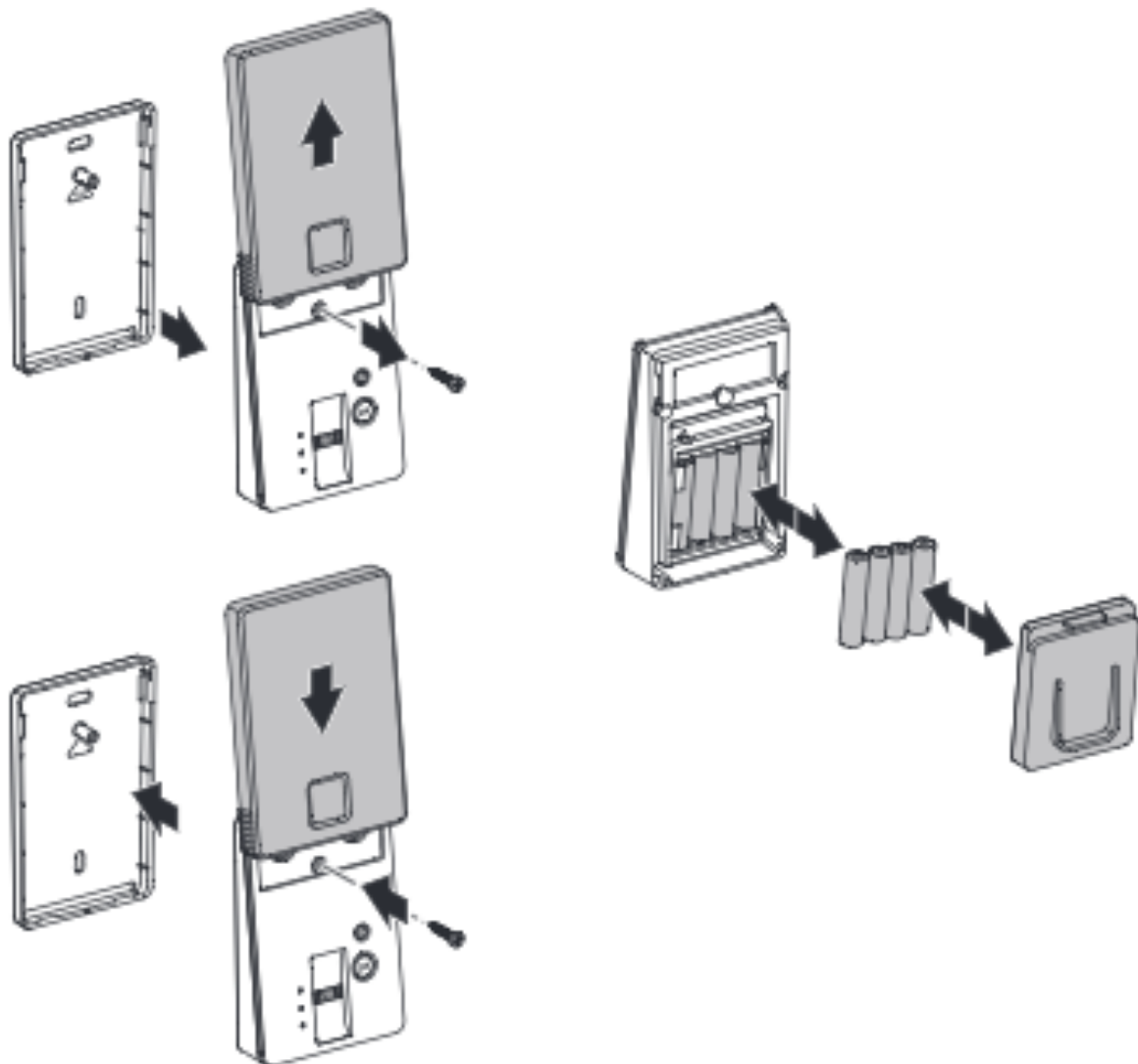

Gli apparecchi usati e le batterie non devono essere smaltiti tra i rifiuti domestici!



## 5. Configurazione

Alla fine del documento è riportata una tabella per la registrazione delle dita master e utente.

## 6. Specifiche tecniche



AAA, 1,5V



°C

-20



°C

+60



IP54



868,3 MHz (max. 0,15 mW)  
433,92 MHz (max. 0,13 mW)

## NL Gebruiksaanwijzing



### 1. Informatie bij dit product

- Originele gebruiksaanwijzing.
- Onderdeel van het product.
- Moet absoluut worden gelezen en bewaard.
- Auteursrechtelijk beschermd.
- Herdruk, ook gedeeltelijk, alleen met onze toestemming.
- Onder voorbehoud van wijzigingen in het belang van de technische vooruitgang.
- De afbeeldingen zijn niet op schaal.

#### Vereenvoudigde EU-conformiteitsverklaring

Hierbij verklaar ik, Marantec Antriebs- und Steuerungstechnik GmbH & Co. KG, dat het type radioapparatuur Digital 528 conform is met Richtlijn 2014/53/EU.

De volledige tekst van de EU-conformiteitsverklaring kan worden geraadpleegd op het volgende internetadres: [www.marantec.com](http://www.marantec.com)



### WAARSCHUWING!

#### Kans op letsel door ongecontroleerde deurbediening!

- Gebruik de besturing of de handzender alleen maar als er zich geen personen of voorwerpen in het bewegingsbereik van de deur bevinden.
- Zorg ervoor dat de besturing en handzender niet door kinderen of onbevoegden kunnen worden gebruikt.
- Zorg ervoor dat de handzender niet per ongeluk kan worden ingedrukt (bijv. in uw zak).



### INFORMATIE

De documentatie van de handzender of ontvanger moet in acht worden genomen.

Praktische informatie en een videohandleiding voor de instelling van het apparaat zijn in het FAQ-gedeelte op de volgende website te vinden:

[www.marantec.com](http://www.marantec.com)



## 2. Productoverzicht

### 2.1 Leveringspakket

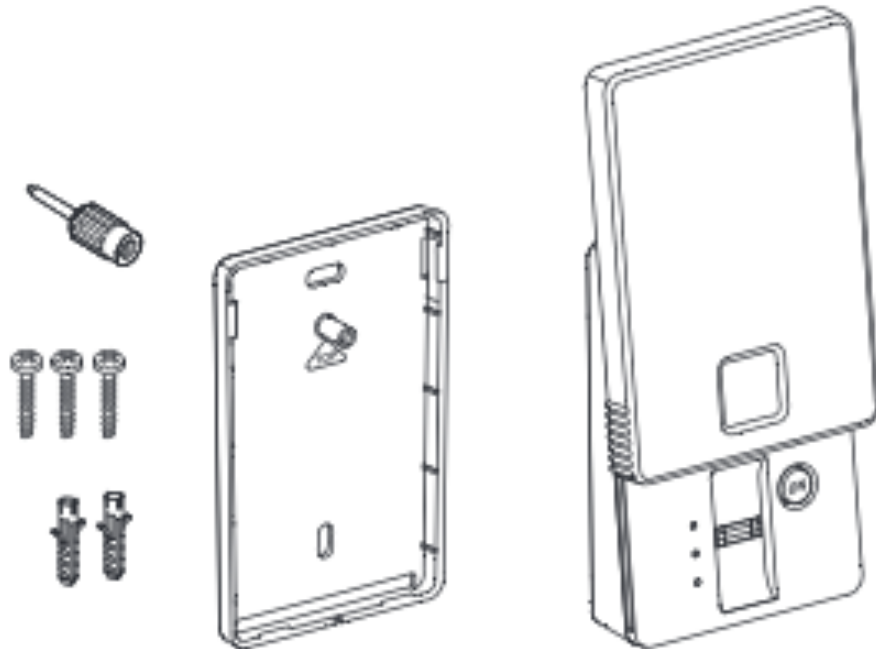

### 2.2 Montage

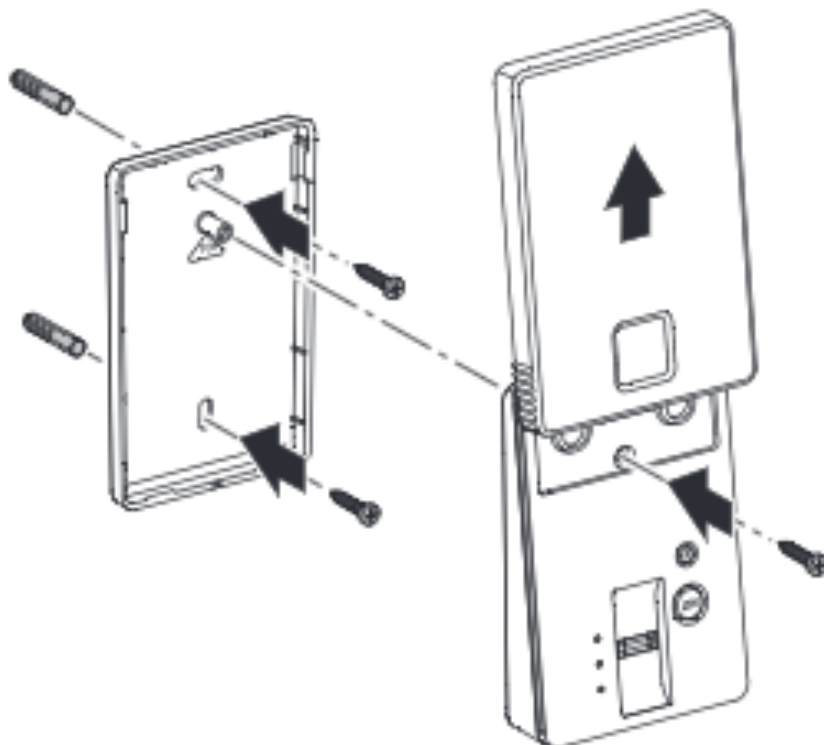

## 2.3 Overzicht

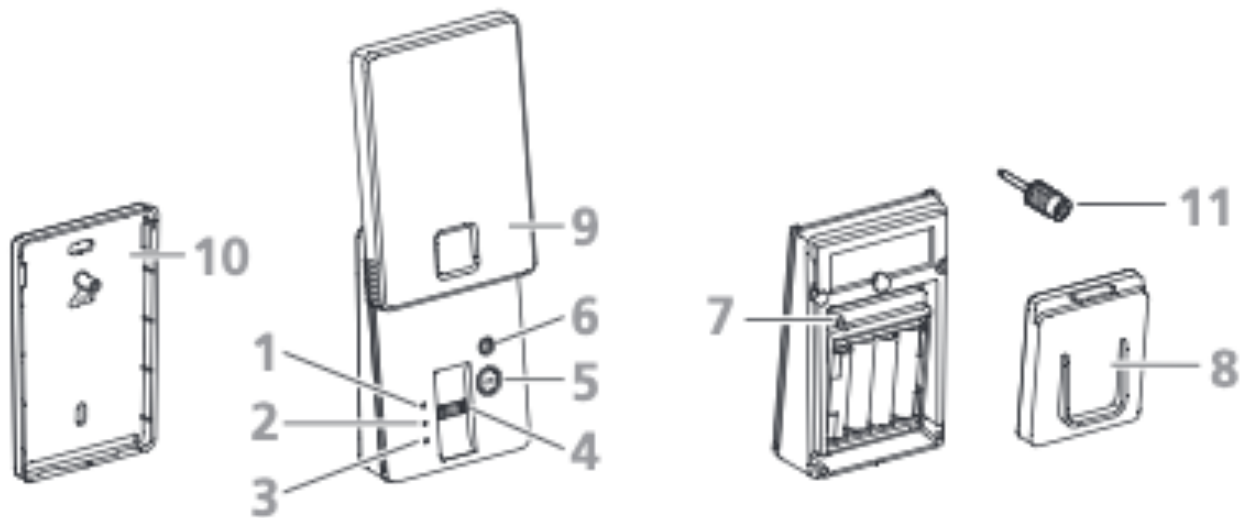

### Legenda

- |   |                      |    |  |
|---|----------------------|----|--|
| 1 | Ledindicator rood    | 7  | Achterste programmeertoets                     |
| 2 | Ledindicator geel    | 8  | Deksel batterijvakje                           |
| 3 | Ledindicator groen   | 9  | Afdekking                                      |
| 4 | Leesmodule           | 10 | Wandhouder                                     |
| 5 | Power-toets (ON)     | 11 | Programmeerpen voor achterste programmeertoets |
| 6 | Programmeertoets (P) |    |  |

## 2.4 Ledindicatoren



Ledje uit



Ledje knippert langzaam



Ledje brandt



Ledje knippert snel



Ledje flikkert



Ledje knippert tweemaal en snel

### 3. Inbedrijfstelling

- 2 master-vingerafdrukken bieden toegang tot de programmeerfuncties.
- Er kunnen 20 gebruikersvingerafdrukken worden gescand, verdeeld over 2 radiokanalen (A + B). Elk radiokanaal kan een aandrijvingsfunctie of een aandrijving bedienen.















#### 3.1 Master-vingerafdruk scannen

- Alleen bij eerste inbedrijfstelling of na een reset noodzakelijk.
- Er moeten 2 verschillende master-vingerafdrukken worden gescand om de programmering met succes af te ronden.
- Master- en gebruiker-vingerafdrukken moeten van verschillende vingers zijn.

<p>1.</p>	<ul style="list-style-type: none"> <li>• Afdekking wegschuiven of power-toets (ON) indrukken.</li> <li>- Geen master-vingerafdruk gescand.</li> </ul>		<p>20 s</p>
<p>2.</p>	<ul style="list-style-type: none"> <li>• Nieuwe master-vingerafdruk 1 volledig over de leesmodule trekken.</li> </ul>		<p>2 s</p>
<p>3.</p>	<ul style="list-style-type: none"> <li>- Geen master-vingerafdruk 2 gescand.</li> </ul>		<p>20 s</p>
<p>4.</p>	<ul style="list-style-type: none"> <li>• Nieuwe master-vingerafdruk 2 volledig over de leesmodule trekken.</li> </ul>		<p>2 s</p>
<p>5.</p>	<ul style="list-style-type: none"> <li>- Apparaat schakelt in de standby-modus.</li> </ul>		<p>20 s</p>

### 3.2 Gebruikersvingerafdruk scannen

- Een gebruiker-vingerafdruk mag niet al als master-vinger worden gebruikt, zodat een permanente en goede werking is gewaarborgd.
- Als het geheugen vol is (20 gebruikersvingerafdrukken), verschijnt er een waarschuwing.
- Een bestaande gebruikersvingerafdruk verwijderen en er opnieuw een scannen, of
- zonder voorafgaande verwijdering nogmaals scannen. De nieuwe gebruikersvingerafdruk wordt dan opgeslagen en vervangt de als eerste gescande gebruikersvingerafdruk. Elke volgende gescande gebruikersvingerafdruk overschrijft de 2e, 3e, 4e, etc..

1.	<ul style="list-style-type: none"> <li>• Afdekking compleet wegschuiven of power-toets (ON) indrukken.</li> <li>– Apparaat schakelt in de standby-modus.</li> </ul>	  	20 s
2.	<ul style="list-style-type: none"> <li>• Programmeertoets (P) gedurende 4 seconden ingedrukt houden.</li> </ul>	  	20 s 20 s
3.	<ul style="list-style-type: none"> <li>• Geldige master-vinger volledig over de leesmodule trekken.</li> </ul>	  	20 s 20 s 2 s
4.	Radiokanaal A	  	20 s 20 s
5.	<p>Radiokanaal A:</p> <ul style="list-style-type: none"> <li>• Nieuwe gebruikersvinger volledig over de leesmodule trekken.</li> <li>– De volgende gebruikersvingerafdrukken kunnen na elkaar worden gescand. Stap 5 zolang herhalen totdat alle gebruikersvingerafdrukken voor radiokanaal A zijn gescand.</li> </ul>	  	20 s 20 s 2 s

**Mogelijke fouten**

- Gebruikersvingerafdruk of onbekende vingerafdruk gescand, de programmeermodus wordt onmiddellijk beëindigd.
- Stap opnieuw uitvoeren.
  
- Het geheugen is vol, de programmering wordt onmiddellijk beëindigd.
- Niet benodigde gebruikersvingerafdruk verwijderen en stappen opnieuw uitvoeren, of
- Zolang het gele ledje nog brandt, stappen opnieuw uitvoeren om een bestaande vingerafdruk te overschrijven. Om meer vingerafdrukken te overschrijven, moet dit proces elke keer opnieuw worden opgestart.



6.

- Wissel naar radiokanaal B (optioneel):
- Programmeertoets (P) indrukken.

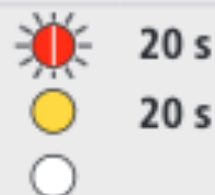

Radiokanaal B:

7.

- Nieuwe gebruikersvinger volledig over de leesmodule trekken.
- De volgende gebruikersvingerafdrukken kunnen na elkaar worden gescand. Stap 7 zolang herhalen totdat alle gebruikersvingerafdrukken voor radiokanaal B zijn gescand.

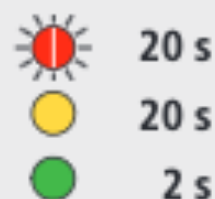

**Mogelijke fouten**

- zie punt 5
  
- Wacht tot het rode ledje uitgaat of houd programmeertoets (P) gedurende 4 seconden ingedrukt.
- Apparaat schakelt in de bedrijfsmodus.





### 3.3 Apparaat programmeren

- Het apparaat beschikt over twee radiokanalen (A + B). Via een in het apparaat gescande gebruikersvingerafdruk wordt het desbetreffende radiokanaal in de aandrijving of besturing geprogrammeerd.

- Apparaat van de muur halen.
  - Deksel batterijvakje verwijderen.

- Aandrijving, besturing of ontvanger in gereedheid voor draadloos leren brengen. Op de aandrijving/besturing knippert het draadloos-symbool .



De documentatie van de aandrijving of ontvanger moet in acht worden genomen.

- Afdekking wegschuiven of power-toets (ON) indrukken.
  - Apparaat schakelt in de standby-modus.



- Op de achterste programmeertoets drukken.



- Geldige master-vinger volledig over de leesmodule trekken.













#### Mogelijke fouten

- Gebruikersvingerafdruk of onbekende vingerafdruk gescand, de programmeermodus wordt onmiddellijk beëindigd.
- Stap opnieuw uitvoeren.







6.	<ul style="list-style-type: none"> <li>• Nieuwe gebruikersvinger volledig over de leesmodule trekken.</li> <li>– Er wordt een programmeertelegram verzonden.</li> </ul>	  <b>20 s</b>  <b>2 s</b>
<p><b>Mogelijke fouten</b></p> <ul style="list-style-type: none"> <li>– Master-vingerafdruk of onbekende vingerafdruk gescand, de programmeermodus wordt onmiddellijk beëindigd.</li> <li>• Stap opnieuw uitvoeren.</li> </ul>		 <b>2 s</b>  
7.	<ul style="list-style-type: none"> <li>– Apparaat schakelt in de gebruikersgereedheidsmodus.</li> </ul>	  <b>20 s</b> 
8.	<p>De gereedheid voor draadloos leren op de aandrijving, besturing of ontvanger beëindigen.                  Op de aandrijving/besturing gaat het draadloos-symbool  uit.</p> <p> De documentatie van de aandrijving of ontvanger moet in acht worden genomen.</p>	
9.	<ul style="list-style-type: none"> <li>– Voor het programmeren van radiokanaal B stappen opnieuw uitvoeren en gebruikersvingerafdruk voor radiokanaal B scannen.</li> </ul>	
10.	<ul style="list-style-type: none"> <li>• Deksel batterijvakje aanbrengen.</li> <li>• Apparaat op de muur bevestigen.</li> </ul>	

## 4. Bediening

### 4.1 Functie activeren

1.	<ul style="list-style-type: none"> <li>• Afdekking wegschuiven of power-toets (ON) indrukken.</li> <li>– Apparaat schakelt in de gebruikersgereedheidsmodus.</li> </ul>	  <b>20 s</b> 
----	---	---

- 2.
- Nieuwe gebruikersvinger volledig over de leesmodule trekken.
  - Bij 10 x knipperen de batterijen vervangen.

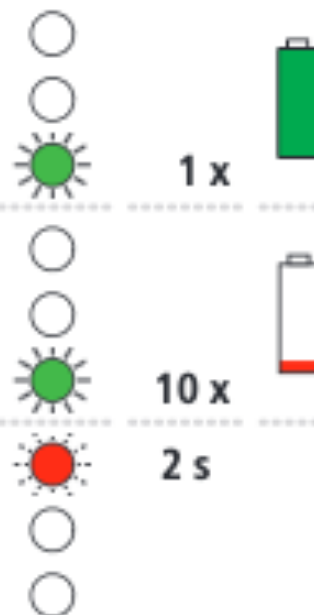

**Mogelijke fouten**

- Onbekende vingerafdruk.
- Master-vingerafdruk gescand.

**4.2 Gebruikersvingerafdruk verwijderen.**

- 1.
- Afdekking wegschuiven of power-toets (ON) indrukken.
  - Apparaat schakelt in de standby-modus.



- 2.
- Programmeertoets (P) gedurende 4 seconden ingedrukt houden.



- 3.
- Programmeertoets (P) gedurende 4 seconden ingedrukt houden.









- 4.
- Geldige master-vinger volledig over de leesmodule trekken.



<p><b>Mogelijke fouten</b></p> <ul style="list-style-type: none"> <li>– Onbekend vingerafdruk gescand, de programmeermodus wordt onmiddellijk beëindigd.</li> <li>• Stap opnieuw uitvoeren.</li> </ul>	 2 s  
<p><b>5. Afzonderlijke gebruikersvingerafdruk verwijderen</b></p> <ul style="list-style-type: none"> <li>• Te verwijderen gebruikersvinger volledig over de leesmodule trekken.</li> </ul>	 20 s  20 s  2 s
<p><b>Alle gebruikersvingerafdrukken verwijderen</b></p> <ul style="list-style-type: none"> <li>• Programmeertoets (P) indrukken.</li> </ul>	 20 s  20 s  > 2 s
<p><b>6.</b></p> <ul style="list-style-type: none"> <li>– Apparaat schakelt naar de gebruikersgereedheidsmodus en de bedrijfsgereedheidsmodus.</li> </ul>	  20 s 

### 4.3 RESET

<ul style="list-style-type: none"> <li>– Alle master- en gebruikersvingerafdrukken worden verwijderd en nieuwe radiocodes gegenereerd.</li> </ul>	
<p><b>1.</b></p> <ul style="list-style-type: none"> <li>• Apparaat van de muur halen.</li> <li>• Deksel batterijvakje verwijderen.</li> <li>• Afdekking openschuiven.</li> <li>• Een van de batterijen verwijderen.</li> </ul>	
<p><b>2.</b></p> <ul style="list-style-type: none"> <li>• Bij ingedrukte achterste programmeertoets de batterij weer plaatsen.</li> <li>• Achterste programmeertoets loslaten.</li> </ul>	  
<p><b>3.</b></p> <ul style="list-style-type: none"> <li>– Apparaat is teruggezet naar de fabrieksinstellingen.</li> <li>– Geen master-vingerafdruk gescand. Nieuwe master-vingerafdruk scannen.</li> </ul>	 20 s  

## 4.4 Batterij vervangen

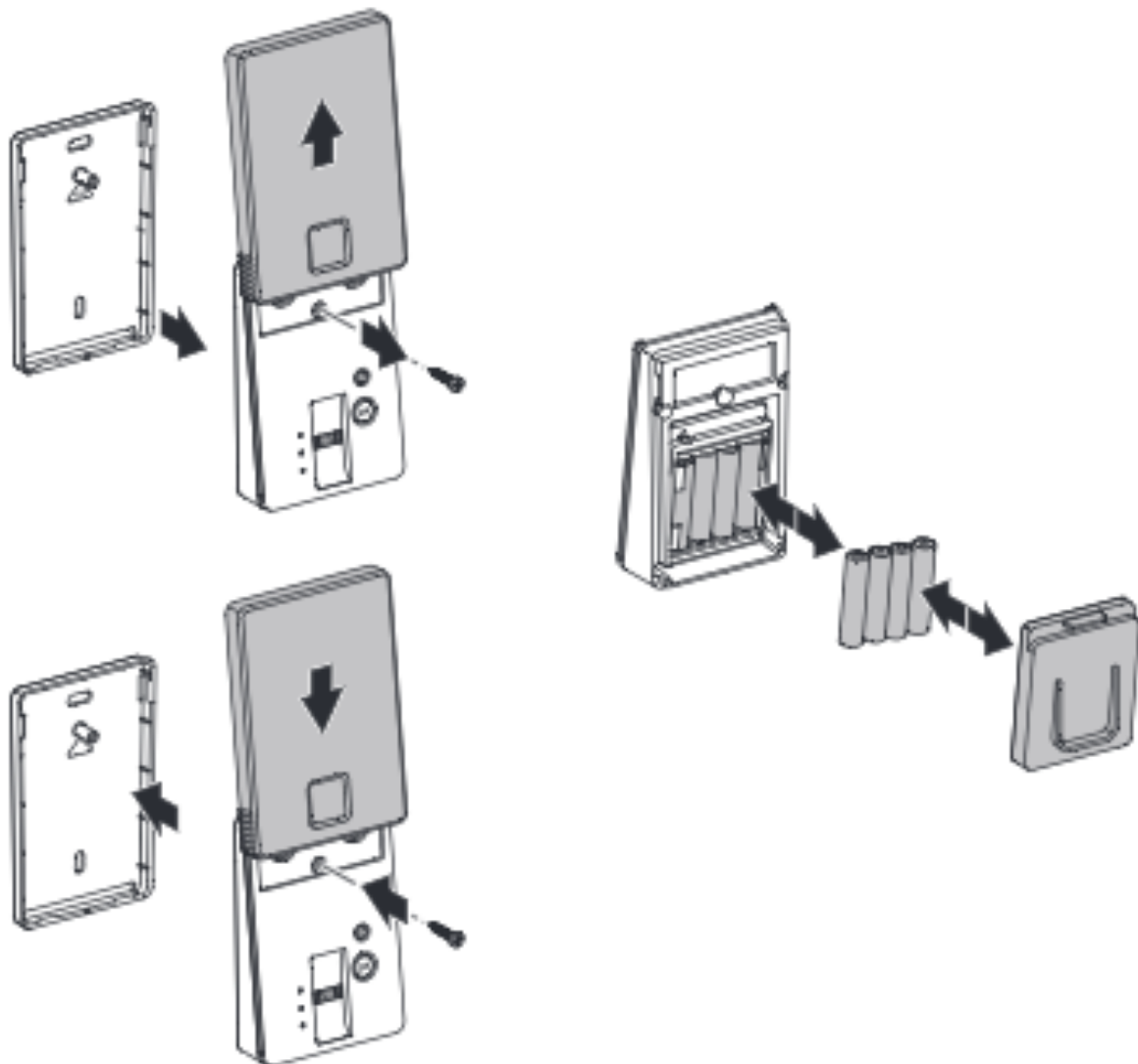

Oude apparaten en batterijen mogen niet worden weggegooid bij het normale huishoudelijke afval!



## 5. Overzicht

Een tabel voor het invoeren van de master- en gebruiker-vingerafdrukken bevindt zich aan het einde van het document.

## 6. Technische gegevens



AAA, 1,5V



°C

-20



°C

+60



IP54



868,3 MHz (max. 0,15 mW)  
433,92 MHz (max. 0,13 mW)

## PL Instrukcja obsługi



### 1. O niniejszym wyrobie

- Instrukcja oryginalna.
- Integralna część wyrobu.
- Należy koniecznie przeczytać i przechowywać.
- Chroniona prawami autorskimi.
- Dodruk, również fragmentaryczny, wyłącznie z za naszą zgodą.
- Zastrzega się prawo do wprowadzania zmian służących optymalizacjom technicznym.
- Prezentacje graficzne mogą nie być wyskalowane.

#### Uproszczoną deklarację zgodności UE

Marantec Antriebs- und Steuerungstechnik GmbH & Co. KG niniejszym oświadcza, że typ urządzenia radiowego Digital 528 jest zgodny z dyrektywą 2014/53/UE.

Pełny tekst deklaracji zgodności UE jest dostępny pod następującym adresem internetowym: [www.marantec.com](http://www.marantec.com)



#### OSTRZEŻENIE!

##### Niebezpieczeństwo wypadku spowodowane niekontrolowanym aktywowaniem bramy!

- Prosimy aktywować sterownik lub ręczny nadajnik sterowania zdalnego (pilot) tylko wtedy, jeśli w strefie ruchu bramy nie będą znajdowały się osoby lub przedmioty.
- Prosimy zapewnić, aby sterownik i ręczny nadajnik sterowania zdalnego (pilot) nie znalazł się w rękach dzieci lub osób nieupoważnionych.
- Prosimy zapewnić, aby ręczny nadajnik sterowania zdalnego (pilot) nie został przypadkowo aktywowany (np. w kieszeni spodni).



#### ODSYŁACZ

Należy przestrzegać zaleceń zawartych w dokumentacji napędu lub odbiornika. Przydatne informacje i film instruktażowy dla ustawień urządzenia można znaleźć w części FAQ na poniższej stronie internetowej:



## 2. Wygląd wyrobu

### 2.1 Zakres dostawy

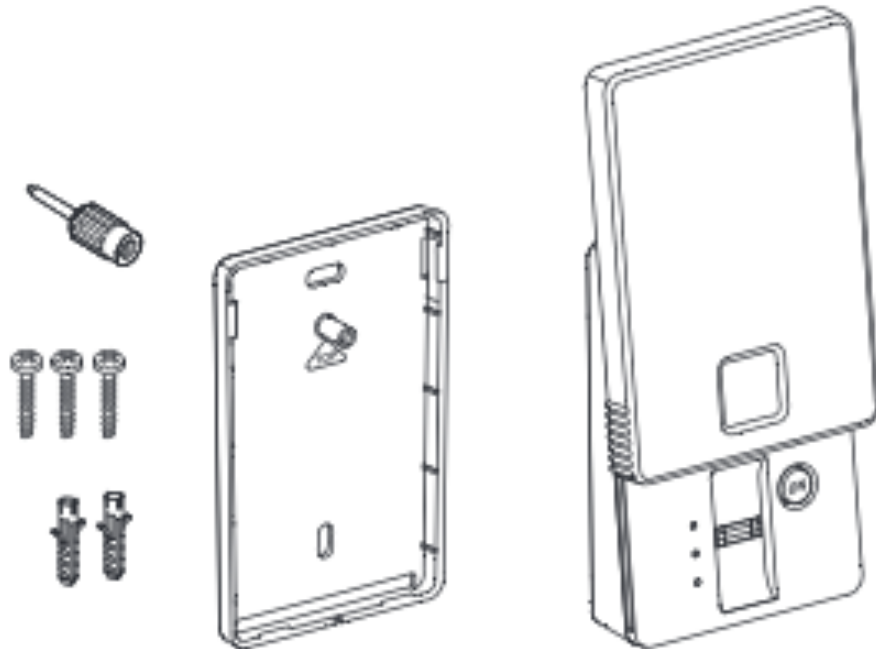

### 2.2 Montaż

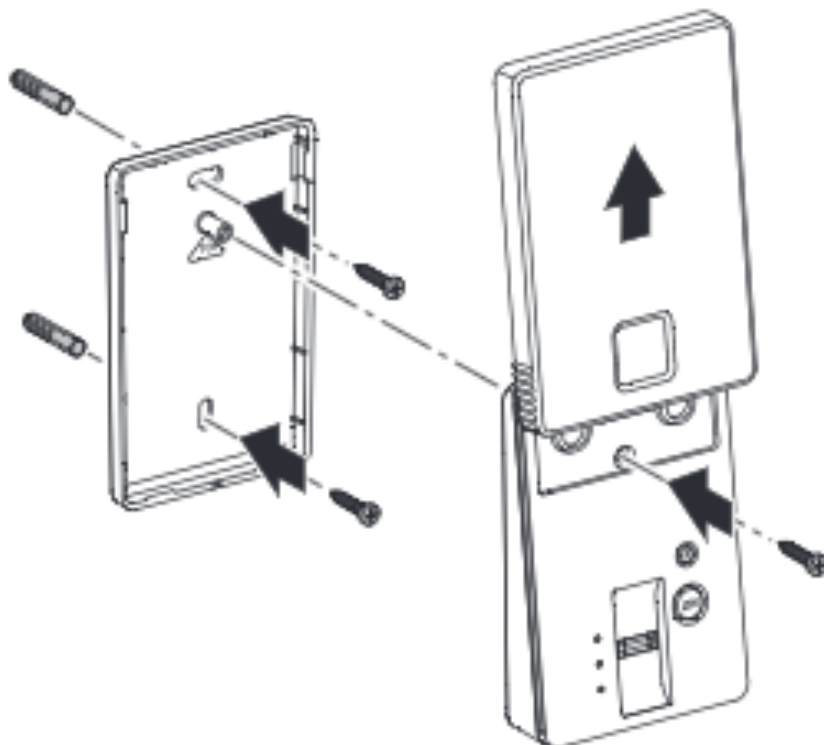

## 2.3 Widok

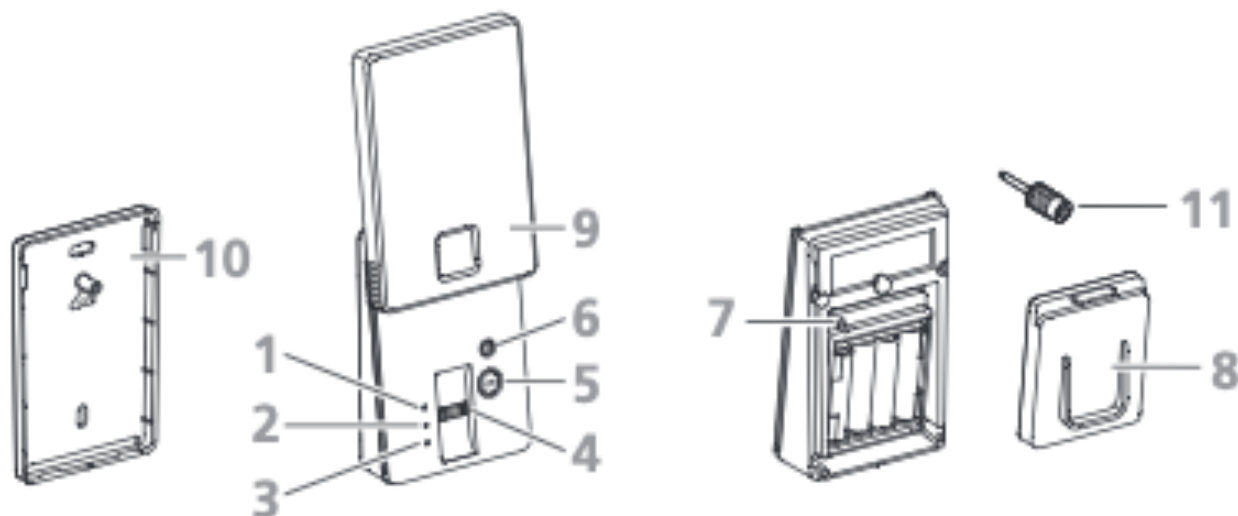

### Legenda

- |   |                              |    |   |
|---|------------------------------|----|---|
| 1 | Prezentacja diodowa czerwona | 8  | Pokrywa kasety baterii                                    |
| 2 | Prezentacja diodowa żółta    | 9  | Pokrywa   |
| 3 | Prezentacja diodowa zielona  | 10 | Uchwyt ścienny  |
| 4 | Moduł odczytu                | 11 | Trzpień programowania dla dolnego przycisku programowania |
| 5 | Włącznik zasilania (ON)      |    |   |
| 6 | Przycisk programowania (P)   |    |   |
| 7 | Tylny przycisk programowania |    |   |

## 2.4 Prezentacje diodowe



Dioda nie świeci się



Dioda miga wolno



Dioda świeci się



Dioda miga szybko



Dioda miga nieregularnie











Dioda miga dwukrotnie i szybko

### 3. Rozruch

- 2 palce Master zapewniają dostęp do funkcji programowania.
- 20 palców użytkowników można zaprogramować i rozdzielić na 2 kanały radiowe (A + B). Na każdym kanale radiowym można obsługiwać funkcję napędu lub napęd.





#### 3.1 Programowanie/nauczanie palca Master

- Konieczne tylko przy pierwszym uruchomieniu lub po zresetowaniu.
- Należy zaprogramować/nauczyć 2 różne palce Master w celu pomyślnego zakończenia programowania.
- Palec Master musi być inny niż palec użytkownika.

1.	<ul style="list-style-type: none"> <li>• Nasunąć pokrywę lub nacisnąć przycisk zasilania (ON)</li> <li>– Nie zaprogramowano/nauczono palca Master.</li> </ul>	  	20 s
2.	<ul style="list-style-type: none"> <li>• W pełni przeciągnąć nowy palec Master 1 nad modulem odczytu.</li> </ul>	  	2 s
3.	<ul style="list-style-type: none"> <li>– Nie zaprogramowano/nauczono palca Master 2.</li> </ul>	  	20 s
4.	<ul style="list-style-type: none"> <li>• W pełni przeciągnąć nowy palec Master 2 nad modulem odczytu.</li> </ul>	  	2 s
5.	<ul style="list-style-type: none"> <li>– Urządzenie przechodzi do stanu gotowości do pracy.</li> </ul>	  	20 s

### 3.2 Programowanie/nauczanie palca użytkownika

- Palec użytkownika nie może być już stosowany jako palec master, aby zapewnić trwałe i prawidłowe działanie.
- Po zapełnieniu się pamięci (20 palców użytkowników) pojawia się ostrzeżenie.
- Usunąć jeden występujący palec użytkownika i prowadzić ponownie programowanie/nauczanie lub
- prowadzić je ponownie bez uprzedniego usuwania. Nowy palec użytkownika zostaje zapisany i zastępuje 1. programowany/nauczony palec użytkownika. Każdy następny programowany/nauczony palec użytkownika nadpisuje 2., 3., 4. itd.

1.	<ul style="list-style-type: none"> <li>• Nasunąć całkowicie pokrywę lub nacisnąć przycisk zasilania (ON).</li> <li>– Urządzenie przechodzi do stanu gotowości do pracy.</li> </ul>		20 s
2.	<ul style="list-style-type: none"> <li>• Przycisk programowania (P) trzymać w stanie wciśnięcia przez 4 sekundy.</li> </ul>		20 s 20 s
3.	<ul style="list-style-type: none"> <li>• W pełni przeciągnąć aktualny palec Master nad modulem odczytu.</li> </ul>		20 s 20 s 2 s
4.	Kanał radiowy A		20 s 20 s
5.	<p>Kanał radiowy A:</p> <ul style="list-style-type: none"> <li>• W pełni przeciągnąć nowy palec użytkownika nad modulem odczytu.</li> <li>– Dalsze palce użytkowników można programować/nauczyć jeden po drugim. Krok 5 powtarzać tak długo, aż wszystkie palce użytkowników zostaną dla kanału A zaprogramowane/nauczone.</li> </ul>		20 s 20 s 2 s

### Możliwe błędy

- Po wczytaniu palca użytkownika lub nieznanego palca, tryb programowania zostaje natychmiast zakończony.
- Ponownie wykonać stosowne kroki.
  
- Pamięć pełna, tryb programowania zostaje natychmiast zakończony.
- Usunąć niepotrzebny palec użytkownika i przeprowadzić kroki ponownie lub
- Jak tylko żółta dioda jeszcze się świeci, tak długo przeprowadzać kroki ponownie w celu nadpisania istniejącego palca. W celu nadpisania kilku palców, należy za każdym razem ponownie rozpocząć proces.



6.

- Przejdźcie na kanał radiowy B (opcjonalnie):
- Nacisnąć przycisk programowania (P).

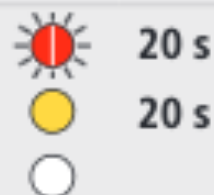

7.

Kanał radiowy B:

- W pełni przeciągnąć nowy palec użytkownika nad modulem odczytu.
- Dalsze palce użytkowników można programować/nauczyć jeden po drugim. Krok 7 powtarzać tak długo, aż wszystkie palce użytkowników zostaną dla kanału B zaprogramowane/nauczone.

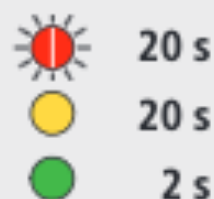

### Możliwe błędy

- patrz punkt 5

8.

- Odczekać, aż czerwona dioda zgaśnie lub przytrzymać przycisk programowania (P) przez 4 sekundy.
- Urządzenie przechodzi do stanu gotowości do pracy.





### 3.3 Zaprogramować/nauczyć urządzenie

- Urządzenie posiada dwa kanały radiowe (A + B). Poprzez palec użytkownika zaprogramowany/nauczony w urządzeniu następuje programowanie/nauczanie poszczególnych kanałów radiowych w napędzie lub w sterowniku.

- Zdemontować urządzenie ze ściany
  - Zdjąć pokrywę kasy baterii.

- Ustawić napęd, sterownik lub odbiornik w stanie gotowości do programowania.

Na napędzie / sterowniku miga symbol komunikacji zdalnej .



Koniecznie przestrzegać dokumentacji napędu lub odbiornika.

- Nasunąć pokrywę lub nacisnąć przycisk zasilania (ON).
  - Urządzenie przechodzi do stanu gotowości do pracy.



- Nacisnąć tylny przycisk programowania.



- W pełni przeciągnąć aktualny palec Master nad modulem odczytu.

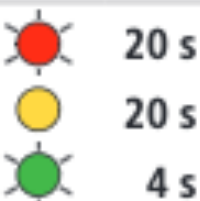











#### Możliwe błędy

- Po wczytaniu palca użytkownika lub nieznanego palca, tryb programowania zostaje natychmiast zakończony.
- Ponownie wykonać stosowne kroki.





6.	<ul style="list-style-type: none"> <li>W pełni przeciągnąć aktualny palec użytkownika nad modulem odczytu.</li> <li>Następuje wysłanie telegramu uczącego.</li> </ul>	  <b>20 s</b>  <b>2 s</b>
<p><b>Możliwe błędy</b></p> <ul style="list-style-type: none"> <li>Po wczytaniu palca Master lub nieznanego palca, tryb programowania zostaje natychmiast zakończony.</li> <li>Ponownie wykonać stosowne kroki.</li> </ul>		 <b>2 s</b>  
7.	<ul style="list-style-type: none"> <li>Urządzenie przechodzi do stanu gotowości do użytku.</li> </ul>	  <b>20 s</b> 
8.	<p>Opuścić tryb gotowości do programowania napędu, sterownika lub odbiornika.</p> <p>Na napędzie / sterowniku gaśnie symbol komunikacji zdalnej .</p> <p> Koniecznie przestrzegać dokumentacji napędu lub odbiornika.</p>	
9.	<ul style="list-style-type: none"> <li>W celu zaprogramowania/nauczenia kanału radiowego B należy ponownie wykonać kroki i zaprogramować/nauczyć palec użytkownika dla kanału B.</li> </ul>	
10.	<ul style="list-style-type: none"> <li>Zamontować pokrywę kasety baterii.</li> <li>Zamontować urządzenie na ścianie.</li> </ul>	

## 4. Obsługa









### 4.1 Wyzwalanie funkcji

1.	<ul style="list-style-type: none"> <li>Nasunąć pokrywę lub nacisnąć przycisk zasilania (ON).</li> <li>Urządzenie przechodzi do stanu gotowości do użytku.</li> </ul>	 <b>20 s</b>
----	--	--







2.	<ul style="list-style-type: none"> <li>• W pełni przeciągnąć aktualny palec użytkownika nad modulem odczytu.</li> <li>– W razie wystąpienia 10 x mignięć wymienić baterię.</li> </ul>		1 x	
			10 x	
	<b>Możliwe błędy</b>		2 s	
	<ul style="list-style-type: none"> <li>– Nieznany palec.</li> <li>– Zaprogramować/nauczyć palec Master.</li> </ul>			

#### 4.2 Usunąć palec użytkownika

1.	<ul style="list-style-type: none"> <li>• Nasunąć pokrywę lub nacisnąć przycisk zasilania (ON).</li> <li>– Urządzenie przechodzi do stanu gotowości do pracy.</li> </ul>		20 s	
2.	<ul style="list-style-type: none"> <li>• Przycisk programowania (P) trzymać w stanie wciśnięcia przez 4 sekundy.</li> </ul>		20 s	20 s
3.	<ul style="list-style-type: none"> <li>• Przycisk programowania (P) trzymać w stanie wciśnięcia przez 4 sekundy.</li> </ul>		20 s	20 s
4.	<ul style="list-style-type: none"> <li>• W pełni przeciągnąć aktualny palec Master nad modulem odczytu.</li> </ul>		20 s	20 s
	<b>Możliwe błędy</b>		2 s	
	<ul style="list-style-type: none"> <li>– Po wczytaniu nieznanego palca, tryb programowania zostaje natychmiast zakończony.</li> </ul>			

5.	<b>Usuwanie poszczególnych palców użytkowników</b>		20 s
	<b>Usuwanie wszystkich palców użytkowników</b>		20 s
			2 s
			20 s
			20 s
			> 2 s
6.	– Urządzenie przechodzi do stanu gotowości do użytku lub do działania.		
			20 s
			

### 4.3 Resetowanie

	– Wszystkie palce Master i użytkowników zostają usunięte i wygenerowane nowe kody komunikacji zdalnej.		
1.	• Zdemontować urządzenie ze ściany.		
	• Zdjąć pokrywę kasy baterii.		
	• Nasunąć pokrywę.		
	• Wyjąć baterię.		
2.	• Ponownie umieścić baterię przy wciśniętym tylnym przycisku programowania.		
	• Puścić tylny przycisk programowania.		
			
3.	– Urządzenie zostało wyzerowane do ustawień fabrycznych.		20 s
	– Nie zaprogramowano/nauczono palca Master.		
	– Programowanie/nauczanie nowych palców Master.		

## 4.4 Wymiana baterii

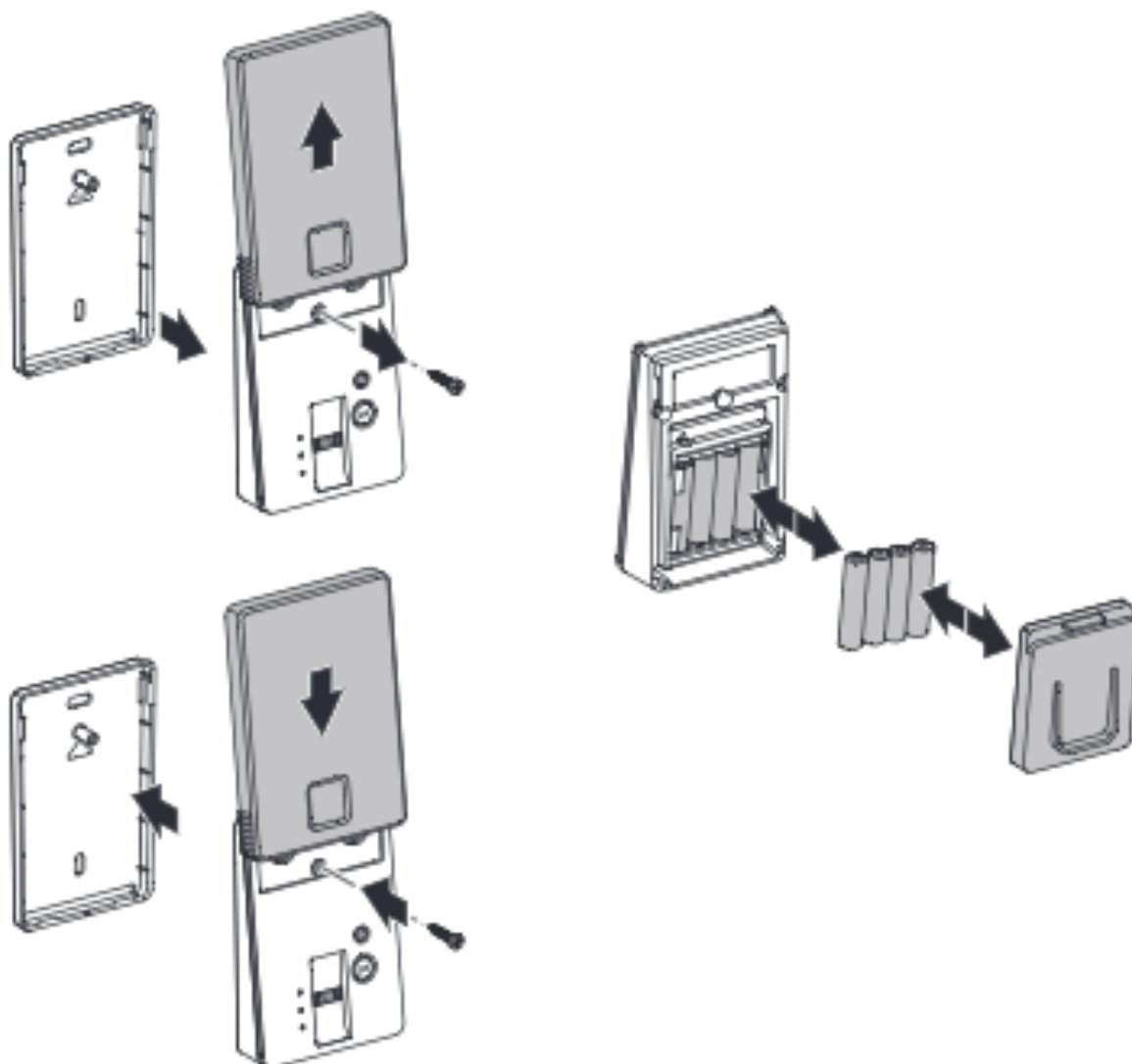

Starych urządzeń i baterii nie wolno usuwać wraz ze śmieciami domowymi!



## 5. Obsadzenie

Tabela do nanoszenia palców Master i palców użytkowników znajduje się na końcu dokumentu.

## 6. Dane techniczne



AAA, 1,5V



°C

-20



°C

+60



IP54



868,3 MHz (max. 0,15 mW)  
433,92 MHz (max. 0,13 mW)

## N Bruksanvisning



### 1. Om dette produktet

- Originalinstruksjon.
- Del av produktet.
- Må ubetinget leses og oppbevares.
- Opphavsrettslig beskyttet.
- Ettertrykk, også i utdrag, er kun tillatt med vår tillatelse.
- Endringer, som brukes for tekniske forbedring, med forbehold.
- Beskrivelser er ikke målestokkfortrolig.

#### Samsvar

Samsvarserklæringen kan hentes på følgende internetside:  
[www.marantec.com](http://www.marantec.com)



#### ADVARSEL!

##### Fare for skade ved ukontrollert portbetjening!

- Bruk styringen eller håndsendere kun når ingen personer eller gjenstander befinner seg i portens bevegelsesområde.
- Vær sikker på, at styring og håndsender ikke blir benyttet av barn eller uvedkommende personer.
- Vær sikker på, at håndsenderen ikke blir betjent av vanvare (f.eks. i lommen).



#### HUSK

Det må tas hensyn til dokumentasjonen til driften og mottakere.  
Nyttig informasjon og en videoveiledning til klargjøring av enheten finner du i FAQ-området på den følgende internettsiden:  
[www.marantec.com](http://www.marantec.com)



## 2. Produktübersicht

### 2.1 Lieferumfang

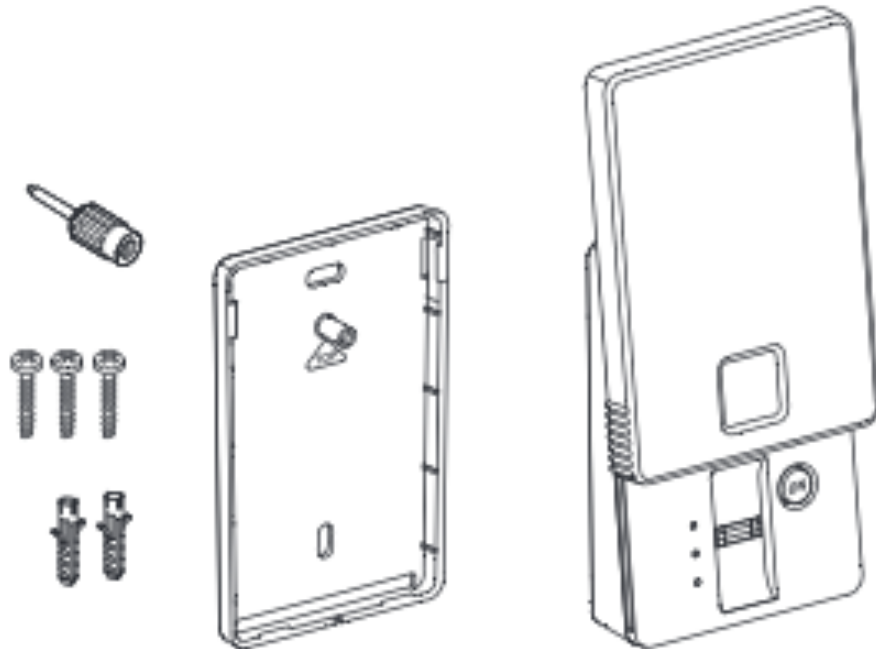

### 2.2 Montage

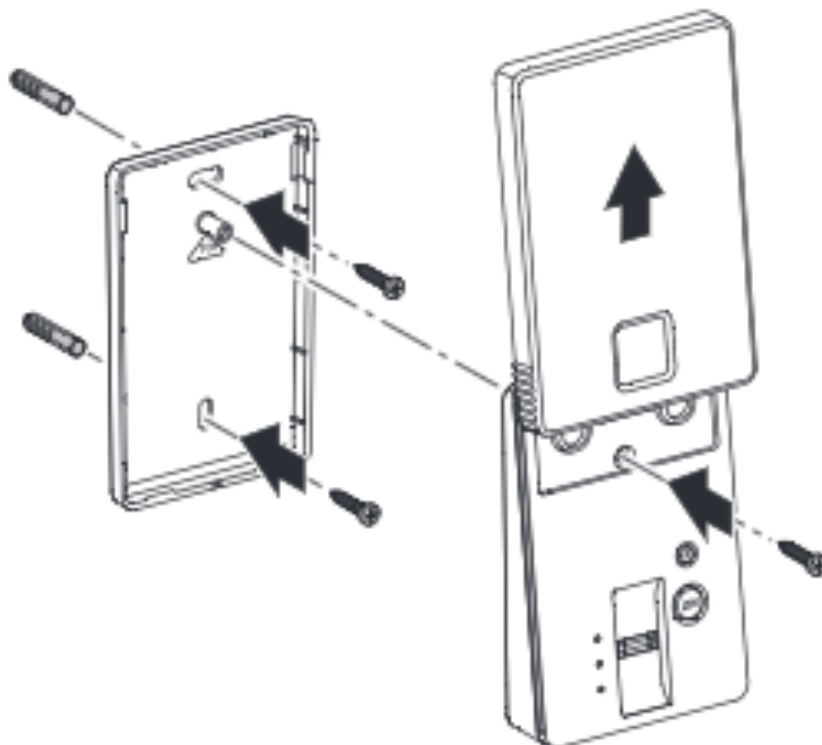

## 2.3 Oversikt

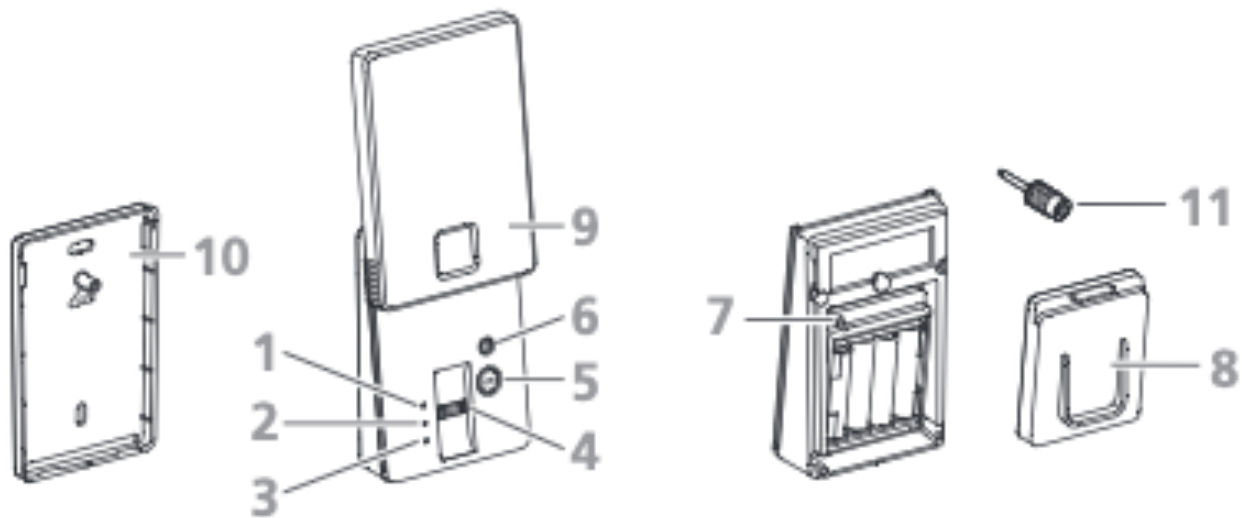

### Tegnforklaring

- |   |                           |    |  |
|---|---------------------------|----|--|
| 1 | LED-anvisning rød         | 7  | Bakre programmeringstast                         |
| 2 | LED-anvisning gul         | 8  | Batteriromlokk                                   |
| 3 | LED-anvisning grønn       | 9  | Lokk   |
| 4 | Lesemodul                 | 10 | Veggholder                                       |
| 5 | Power-knapp (ON)          | 11 | Programmeringsstift for bakre programmeringstast |
| 6 | Programmerbar inngang (P) |    |  |

## 2.4 LED-anvisninger



LED av



LED blinker sakte



LED lyser



LED blinker hurtig



LED flimrer



LED blinker to ganger og hurtig

### 3. Igangsetting

- 2 masterfinger garanterer tilgang til programmeringsfunksjonene.
- 20 brukerfingre kan læres inn, fordelt på 2 radiokanaler (A + B). Radiokanalene kan betjene én driftsfunksjon eller én motor.





#### 3.1 Innlæring av masterfinger

- Bare nødvendig ved første gangs bruk eller etter reset.
- 2 master-finger må læres inn for å kunne avslutte programmeringen suksessfullt.
- Master- og bruker-fingre må være forskjellige fingre.

1.	<ul style="list-style-type: none"> <li>• Skyv lokket på, eller trykk på Power-knappen (ON).</li> <li>- Ingen masterfinger innlært.</li> </ul>		20 s
2.	<ul style="list-style-type: none"> <li>• Trekk den nye masterfingeren helt over lesemodulen.</li> </ul>		2 s
3.	<ul style="list-style-type: none"> <li>- Ingen masterfinger 2 innlært.</li> </ul>		20 s
4.	<ul style="list-style-type: none"> <li>• Trekk masterfinger nummer 2 helt over lesemodulen.</li> </ul>		2 s
5.	<ul style="list-style-type: none"> <li>- Apparatet skifter til driftsklart.</li> </ul>		20 s

### 3.2 Innlæring av brukerfingre

- En bruker-finger må ikke allerede brukes som master-finger, slik at en kontinuerlig og korrekt funksjon er garantert.
- Hvis minnet er fullt (20 brukerfingre), vises en varselmelding.
- Slett en eksisterende brukerfingre og gjenta innlæringen på nytt, eller
- gjenta innlæringen en gang til uten forutgående sletting. Den nye brukerfingeren lagres, og erstatter brukerfingeren som ble lært inn første gang. Ytterligere brukerfingre som læres inn, overskriver den andre, tredje, fjerde, osv.

1.	<ul style="list-style-type: none"> <li>• Skyv lokket fullstendig på, eller trykk på power-knappen (ON).</li> <li>– Apparatet skifter til driftsklart.</li> </ul>		20 s
2.	<ul style="list-style-type: none"> <li>• Hold programmeringstasten (P) trykket i 4 sekunder.</li> </ul>		20 s 20 s
3.	<ul style="list-style-type: none"> <li>• Trekk gyldig masterfinger helt over lesemodulen.</li> </ul>		20 s 20 s 2 s
4.	Radiokanal A		20 s 20 s
5.	<p>Radiokanal A:</p> <ul style="list-style-type: none"> <li>• Trekk den nye brukerfingeren over hele lesemodulen.</li> <li>– Ytterligere brukerfingre kan læres inn etter hverandre. Gjenta trinn 5 helt til alle brukerfingrene for radiokanal A er lært inn.</li> </ul>		20 s 20 s 2 s

**Mulige feil**

- Les inn brukerfingeren eller en ukjent finger. Programmeringsmodusen avsluttes med en gang.
- Utfør trinne på nytt.
  
- Minnet fullt, programmeringsmodusen avsluttes med en gang.
- Slett brukerfingre som ikke er nødvendige og utfør trinnene på nytt, eller
- utfør trinnene på nytt så lenge den gule LEDen lyser for å overskrive en eksisterende finger. For å skrive over flere fingre må denne prosessen startes på nytt hver gang.



**6.** Skifte til radiokanal B (ekstrautstyr):

- Trykk på programmeringstasten (P).

**7.** Radiokanal B:

- Trekk den nye brukerfingeren over hele lesemodulen.
- Ytterligere brukerfingre kan læres inn etter hverandre. Gjenta trinn 7 helt til alle brukerfingrene for radiokanal B er lært inn.

**Mulige feil**

- se punkt 5
  
- 8.**
  - Vent til den røde LEDen slukker, eller hold programmeringstasten (P) trykket i 4 sekunder.
  - Apparatet skifter til funksjonsberedskap.



### 3.3 Innlæring av apparat

- Apparatet har to radiokanaler (A + B). Den respektive radiokanalen på motoren eller styringen læres inn via en innlært brukerfinger i apparatet.

- Demonter enheten fra veggen.
  - Ta av batteriromlokket.

- Sett drivenhet, styring eller mottaker i radio-innlæringsmodus. På drivenheten/styringen blinker radiosymbolet .



Dokumentasjonen for drivenheten eller mottakeren må leses og følges.

- Skyv lokket på, eller trykk på Power-knappen (ON).
  - Apparatet skifter til driftsklart.



- Trykk på den bakre programmeringstasten.



- Trekk gyldig masterfinger over hele lesemodulen.



#### Mulige feil

- Les inn brukerfingeren eller en ukjent finger. Programmeringsmodusen avsluttes med en gang.
- Utfør trinne på nytt.





6.	<ul style="list-style-type: none"> <li>• Trekk gyldig brukerfinger over hele lesemodulen.</li> <li>– Et læretelegram sendes ut.</li> </ul>	  	<b>20 s</b>  <b>2 s</b>
<b>Mulige feil</b>		  	<b>2 s</b>
7.	– Apparatet skifter til brukerberedskap.	  	<b>20 s</b>
8.	Avslutt radio-innlæringsmodus på drivenhet, styring eller mottaker. På drivenheten/styringen slukker radiosymbolet  .		
		Dokumentasjonen for drivenheten eller mottakeren må leses og følges.	
9.	– Utfør trinnene på nytt til innlæring av radiokanal B, og les inn brukerfingrene for radiokanal B.		
10.	<ul style="list-style-type: none"> <li>• Sett på batteriromlokket.</li> <li>• Monter apparatet på veggen.</li> </ul>		

## 4. Betjening

### 4.1 Utløse funksjon

1.	<ul style="list-style-type: none"> <li>• Skyv lokket på, eller trykk på Power-knappen (ON).</li> <li>– Apparatet skifter til brukerberedskap.</li> </ul>	  	<b>20 s</b>
----	--	---	-------------

- 2.
- Trekk gyldig brukerfinger over hele lesemodulen.
  - Ved 10 blink må batteriene skiftes ut.



1 x



10 x



**Mulige feil**

- Ukjent finger.
- Les inn masterfinger.



2 s

**4.2 Sletting av brukerfingre**

- 1.
- Skyv lokket på, eller trykk på Power-knappen (ON).
  - Apparatet skifter til driftsklart.



20 s

- 2.
- Hold programmeringstasten (P) trykket i 4 sekunder.



20 s

20 s

- 3.
- Hold programmeringstasten (P) trykket i 4 sekunder.



20 s

20 s

- 4.
- Trekk gyldig masterfinger over hele lesemodulen.



20 s

20 s

**Mulige feil**

- Les inn en ukjent finger.
- Programmeringsmodusen avsluttes med en gang.
- Iltfar trinnene nå nytt









2 s

5.	<b>Sletting av én enkelt brukerfinger</b> • Trekk brukerfingeren som skal slettes over hele lesemodulen.		20 s
			20 s
			2 s
6.	<b>Sletting av alle brukerfingerene</b> • Trykk på programmeringstasten (P).		20 s
			20 s
			> 2 s
6.	– Apparatet skifter over til brukerberedskap eller funksjonsberedskap.	  	20 s

### 4.3 Reset

– Alle master- og brukerfingerene slettes, og nye radiokoder genereres.

1.	• Demonter enheten fra veggen. • Ta av batteriomlokket. • Skyv lokket opp. • Ta ut et batteri.		
2.	• Sett i batteriet igjen med nedtrykket programmeringstast. • Slipp den bakre programmeringstasten.	  	
3.	– Apparatet er resatt til fabrikkinnstillinger. – Ingen master-finger innlært. Lær inn ny master-finger.	  	20 s

## 4.4 Bytte batteri

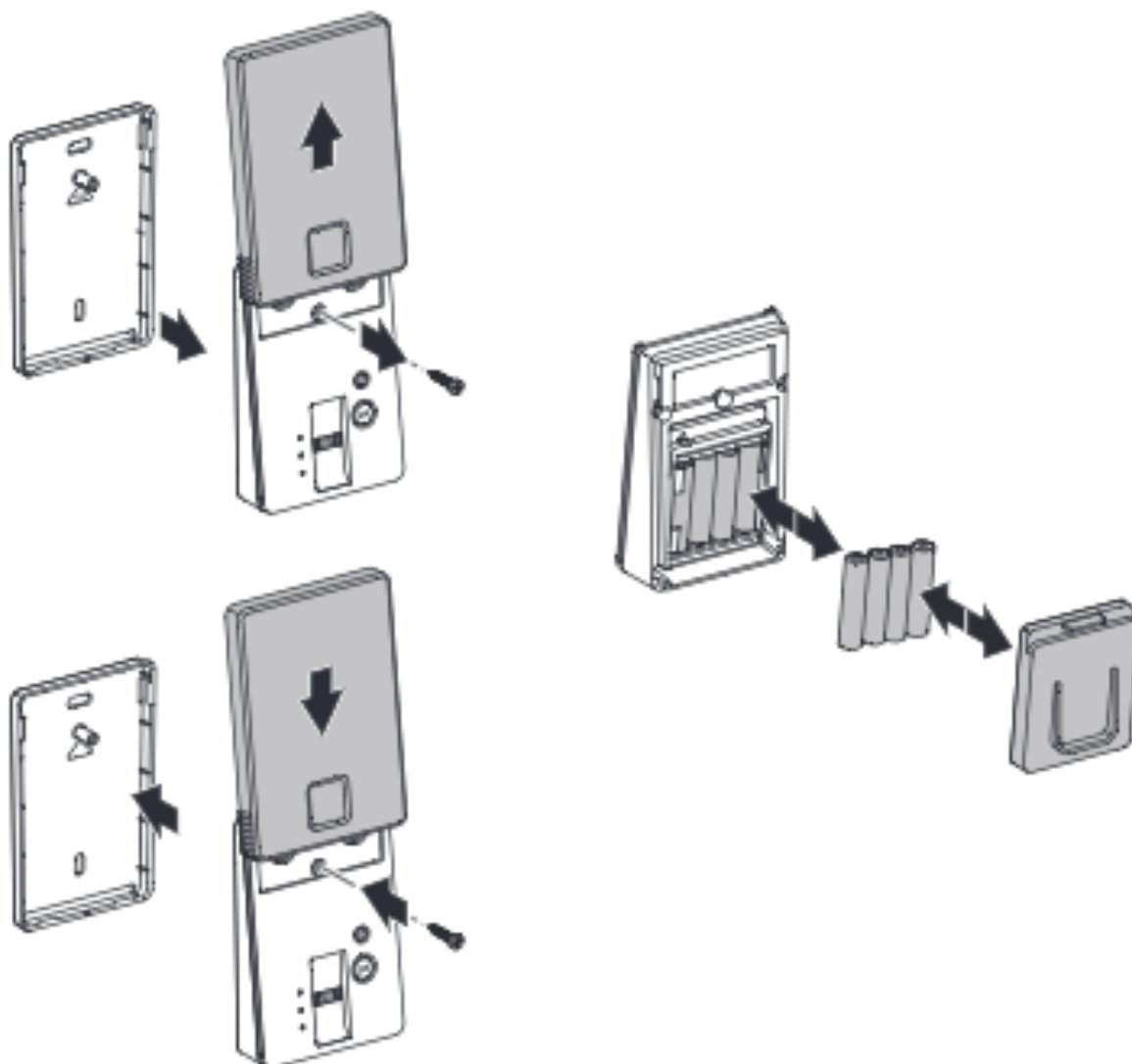

Gamle apparater og batterier må ikke kastes i husholdningsavfallet!



## 5. Belegg

En tabell for føre inn master- og bruker-fingrene finner du til slutt i dokumentet.

## 6. Tekniske data



AAA, 1,5V



°C

-20



°C

+60



IP54



868,3 MHz (max. 0,15 mW)  
433,92 MHz (max. 0,13 mW)



A:



B:

Master 1:



Master 2:



1.



2.



3.



4.



5.



6.



7.



8.





9.		
10.		
11.		
12.		
13.		
14.		
15.		
16.		
17.		
18.		
19.		
20.		



1 - D/GB/F/E/I/NL/PL/N/KD 360427 - M - 0.5 - 1114